

# Concepts in Electric Circuits

Dr. Wasif Naeem

Dr. Wasif Naeem

---

# Concepts in Electric Circuits

---

---

Concepts in Electric Circuits

© 2009 Dr. Wasif Naeem & Ventus Publishing ApS

ISBN 978-87-7681-499-1

# Contents

	<b>Preface</b>	<b>8</b>
<b>1</b>	<b>Introduction</b>	<b>9</b>
1.1	Contents of the Book	9
<b>2</b>	<b>Circuit Elements and Sources</b>	<b>11</b>
2.1	Introduction	11
2.2	Current	11
2.3	Voltage or Potential Difference	13
2.4	Circuit Loads	13
2.5	Sign Convention	15
2.6	Passive Circuit Elements	16
2.6.1	Resistor	16
2.6.2	Capacitor	17
2.6.3	Inductor	18
2.7	DC Sources	19
2.7.1	DC Voltage Source	19



Discover the truth at [www.deloitte.ca/careers](http://www.deloitte.ca/careers)

**Deloitte.**

© Deloitte & Touche LLP and affiliated entities.



<b>2.7.2</b>	<b>DC Current Source</b>	<b>22</b>
2.8	Power	23
2.9	Energy	25
<b>3</b>	<b>Circuit Theorems</b>	<b>27</b>
3.1	Introduction	27
3.2	Definitions and Terminologies	27
3.3	Kirchoff's Laws	28
3.3.1	Kirchoff's Voltage Law (KVL)	28
3.3.2	Kirchoff's Current Law (KCL)	32
3.4	Electric Circuits Analysis	34
3.4.1	Mesh Analysis	34
3.4.2	Nodal Analysis	36
3.5	Superposition Theorem	40
3.6	Thévenin's Theorem	42
3.7	Norton's Theorem	45
3.8	Source Transformation	46
3.9	Maximum Power Transfer Theorem	48
3.10	Additional Common Circuit Configurations	48
3.10.1	Supernode	49

© 2013 Accenture. All rights reserved.

be > your degree

Bring your talent and passion to a global organization at the forefront of business, technology and innovation. Discover how great you can be.

Visit [accenture.com/bookboon](http://accenture.com/bookboon)

**Be greater than.**  
consulting | technology | outsourcing

**accenture**  
High performance. Delivered.



3.10.2	Supermesh	50
3.11	Mesh and Nodal Analysis by Inspection	51
3.11.1	Mesh Analysis	52
3.11.2	Nodal Analysis	52
<b>4</b>	<b>Sinusoids and Phasors</b>	<b>54</b>
4.1	Introduction	54
4.2	Sinusoids	54
4.2.1	Other Sinusoidal Parameters	56
4.3	Voltage, Current Relationships for R, L and C	58
4.4	Impedance	59
4.5	Phasors	60
4.6	Phasor Analysis of AC Circuits	65
4.7	Power in AC Circuits	68
4.8	Power Factor	70
4.8.1	Power Factor Correction	71
<b>5</b>	<b>Frequency Response</b>	<b>73</b>
5.1	Introduction	73
5.2	Frequency Response	74

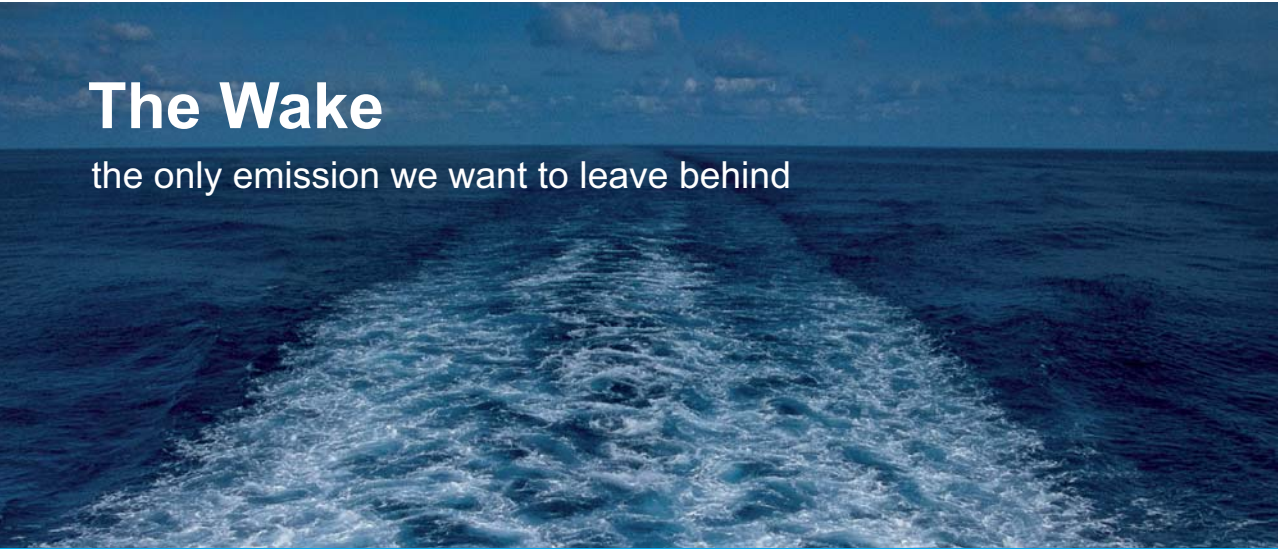

# The Wake

the only emission we want to leave behind

[Low-speed Engines](#)
[Medium-speed Engines](#)
[Turbochargers](#)
[Propellers](#)
[Propulsion Packages](#)
[PrimeServ](#)

The design of eco-friendly marine power and propulsion solutions is crucial for MAN Diesel & Turbo. Power competencies are offered with the world's largest engine programme – having outputs spanning from 450 to 87,220 kW per engine. Get up front! Find out more at [www.mandieselturbo.com](http://www.mandieselturbo.com)

Engineering the Future – since 1758.

## MAN Diesel & Turbo



5.3	Filters	75
5.3.1	Low Pass Filter	75
5.3.2	High Pass Filter	78
5.3.3	Band Pass Filter	80
5.4	Bode Plots	80
5.4.1	Approximate Bode Plots	81
 <b>Appendix A: A Cramer's Rule</b>		 <b>86</b>

FREE  
30 days trial!

# SMS from your computer

...Sync'd with your Android phone & number

Go to

[BrowserTexting.com](http://BrowserTexting.com)

and start texting from your computer!

**BrowserTexting**

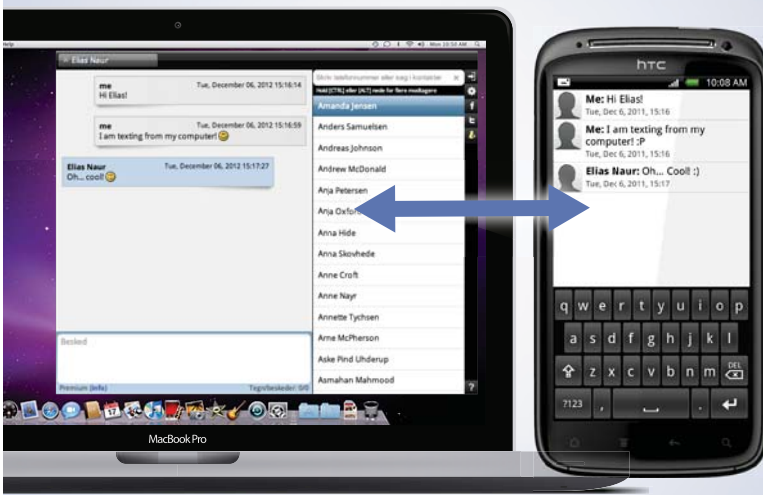

# Preface

This book on the subject of electric circuits forms part of an interesting initiative taken by Ventus Publishing. The material presented throughout the book includes rudimentary learning concepts many of which are mandatory for various engineering disciplines including chemical and mechanical. Hence there is potentially a wide range of audience who could be benefitted.

It is important to bear in mind that this book should not be considered as a replacement of a textbook. It mainly covers fundamental principles on the subject of electric circuits and should provide a solid foundation for more advanced studies. I have tried to keep everything as simple as possible given the diverse background of students. Furthermore, mathematical analysis is kept to a minimum and only provided where necessary.

I would strongly advise the students and practitioners not to carry out any experimental verification of the theoretical contents presented herein without consulting other textbooks and user manuals. Lastly, I shall be pleased to receive any form of feedback from the readers to improve the quality of future revisions.

W. Naeem

Belfast

August, 2009

w.naeem@ee.qub.ac.uk

# Chapter 1

## Introduction

The discovery of electricity has transformed the world in every possible manner. This phenomenon, which is mostly taken as granted, has had a huge impact on people's life styles. Most, if not all modern scientific discoveries are indebted to the advent of electricity. It is of no surprise that science and engineering students from diverse disciplines such as chemical and mechanical engineering to name a few are required to take courses related to the primary subject of this book. Moreover, due to the current economical and environmental issues, it has never been so important to devise new strategies to tackle the ever increasing demands of electric power. The knowledge gained from this book thus forms the basis of more advanced techniques and hence constitute an important part of learning for engineers.

The primary purpose of this compendium is to introduce to students the very fundamental and core concepts of electricity and electrical networks. In addition to technical and engineering students, it will also assist practitioners to adopt or refresh the rudimentary know-how of analysing simple as well as complex electric circuits without actually going into details. However, it should be noted that this compendium is by no means a replacement of a textbook. It can perhaps serve as a useful tool to acquire focussed knowledge regarding a particular topic. The material presented is succinct with numerical examples covering almost every concept so a fair understanding of the subject can be gained.

### 1.1 Contents of the Book

There are five chapters in this book highlighting the elementary concepts of electric circuit analysis. An appendix is also included which provides the reader a mathematical tool to solve a simultaneous system of equations frequently used in this book. Chapter 2 outlines the idea of voltage and current parameters in an electric network. It also explains the voltage polarity and current direction and the technique to correctly measure these quantities in a simple manner. Moreover, the fundamental circuit elements such as a resistor, inductor and capacitor are introduced and their voltage-current relationships are provided. In the end, the concept of power and energy and their mathematical equations in terms of voltage and current are presented. All the circuit elements introduced in this chapter are explicated in the context of voltage and current parameters. For a novice reader, this is particularly helpful as it will allow the student to master the basic concepts before proceeding to the next chapter.

A reader with some prior knowledge regarding the subject may want to skip this chapter although it is recommended to skim through it so a better understanding is gained without breaking the flow.

In Chapter 3, the voltage-current relationships of the circuit elements introduced in Chapter 2 are taken further and various useful laws and theorems are presented for DC<sup>1</sup> analysis. It is shown that these concepts can be employed to study simple as well as very large and complicated DC circuits. It is further demonstrated that a complex electrical network can be systematically scaled down to a circuit containing only a few elements. This is particularly useful as it allows to quickly observe the affect of changing the load on circuit parameters. Several examples are also supplied to show the applicability of the concepts introduced in this chapter.

Chapter 4 contains a brief overview of AC circuit analysis. In particular the concept of a sinusoidal signal is presented and the related parameters are discussed. The AC voltage-current relationships of various circuit elements presented in Chapter 2 are provided and the notion of impedance is explicated. It is demonstrated through examples that the circuit laws and theorems devised for DC circuits in Chapter 3 are all applicable to AC circuits through the use of phasors. In the end, AC power analysis is carried out including the use of power factor parameter to calculate the actual power dissipated in an electrical network.

The final chapter covers AC circuit analysis using frequency response techniques which involves the use of a time-varying signal with a range of frequencies. The various circuit elements presented in the previous chapters are employed to construct filter circuits which possess special characteristics when viewed in frequency domain. Furthermore, the chapter includes the mathematical analysis of filters as well as techniques to draw the approximate frequency response plots by inspection.

---

<sup>1</sup>A DC voltage or current refers to a constant magnitude signal whereas an AC signal varies continuously with respect to time.

## Chapter 2

# Circuit Elements and Sources

### 2.1 Introduction

This chapter provides an overview of most commonly used elements in electric circuits. It also contains laws governing the current through and voltage across these components as well as the power supplied/dissipated and energy storage in this context. In addition, difference between ideal and non-ideal voltage and current sources is highlighted including a discussion on sign convention i.e. voltage polarity and current direction.

The concepts of current and voltage are first introduced as these constitutes one of the most fundamental concepts particularly in electronics and electrical engineering.

### 2.2 Current

Current can be defined as the motion of charge through a conducting material. The unit of current is Ampere whilst charge is measured in Coulombs.

#### Definition of an Ampere

*“The quantity of total charge that passes through an arbitrary cross section of a conducting material per unit second is defined as an Ampere.”*

Mathematically,

$$I = \frac{Q}{t} \text{ or } Q = It \quad (2.1)$$

where  $Q$  is the symbol of charge measured in Coulombs (C),  $I$  is the current in amperes (A) and  $t$  is the time in seconds (s).

The current can also be defined as the rate of charge passing through a point in an electric circuit i.e.

$$i = \frac{dQ}{dt} \quad (2.2)$$

A constant current (also known as direct current or DC) is denoted by the symbol  $I$  whereas a time-varying current (also known as alternating current or AC) is represented by the symbol  $i$  or  $i(t)$ .

*Current is always measured through a circuit element.*

Figure 2.1 demonstrates the use of an ampere-meter or ammeter in series with a circuit element,  $R$ , to measure the current through it.

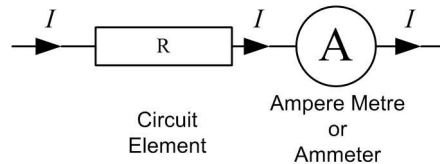

**Figure 2.1:** An ammeter is connected in series to measure current,  $I$ , through the element,  $R$ .

### Example

Determine the current in a circuit if a charge of 80 coulombs (C) passes a given point in 20 seconds (s).

$$Q = 80 \text{ C}, t = 20 \text{ s}, I = ?$$

$$I = \frac{Q}{t} = \frac{80}{20} = 4 \text{ A}$$

# YOUR WORK AT TOMTOM WILL BE TOUCHED BY MILLIONS. AROUND THE WORLD. EVERYDAY.

Join us now on [www.TomTom.jobs](http://www.TomTom.jobs)  
follow us on **LinkedIn**





**#ACHIEVEMORE**
**TOMTOM**

## 2.3 Voltage or Potential Difference

### Definition

*Voltage or potential difference between two points in an electric circuit is 1 V if 1 J (Joule) of energy is expended in transferring 1 C of charge between those points.*

It is generally represented by the symbol  $V$  and measured in volts (V). Note that the symbol and the unit of voltage are both denoted by the same letter, however, it rarely causes any confusion.

The symbol  $V$  also signifies a constant voltage (DC) whereas a time-varying (AC) voltage is represented by the symbol  $v$  or  $v(t)$ .

*Voltage is always measured across a circuit element as demonstrated in Figure 2.2.*

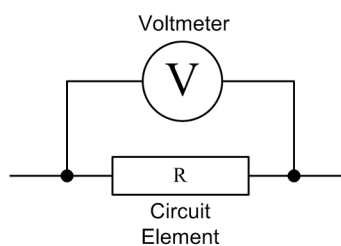

**Figure 2.2:** A voltmeter is connected in parallel with the circuit element,  $R$  to measure the voltage across it.

A voltage source provides the energy or emf (electromotive force) required for current flow. However, current can only exist if there is a potential difference and a physical path to flow. A potential difference of 0 V between two points implies 0 A of current flowing through them. The current  $I$  in Figure 2.3 is 0 A since the potential difference across  $R_2$  is 0 V. In this case, a physical path exists but there is no potential difference. This is equivalent to an open circuit.

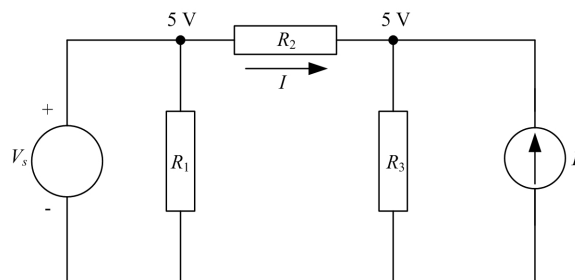

**Figure 2.3:** The potential difference across  $R_2$  is 0 V, hence the current  $I$  is 0 A where  $V_s$  and  $I_s$  are the voltage and current sources respectively.

Table 2.1 summarises the fundamental electric circuit quantities, their symbols and standard units.

## 2.4 Circuit Loads

A load generally refers to a component or a piece of equipment connected to the output of an electric circuit. In its fundamental form, the load is represented by any one or a combination of the following

Quantity	Symbol	Unit
Voltage	$V$	Volts (V)
Current	$I$	Ampere (A)
Charge	$Q$	Coulomb (C)
Power	$P$	Watts (W)
Energy	$W$	Joules (J)
Time	$t$	seconds (s)



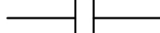
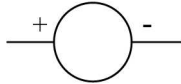

**Table 2.1:** Standard quantities and their units commonly found in electric circuits.

circuit elements

1. Resistor ( $R$ )
2. Inductor ( $L$ )
3. Capacitor ( $C$ )

A load can either be of resistive, inductive or capacitive nature or a blend of them. For example, a light bulb is a purely resistive load whereas a transformer is both inductive and resistive. A circuit load can also be referred to as a *sink* since it dissipates energy whereas the voltage or current supply can be termed as a *source*.

Table 2.2 shows the basic circuit elements along with their symbols and schematics used in an electric circuit. The  $R$ ,  $L$  and  $C$  are all passive components i.e. they do not generate their own emf whereas the DC voltage and current sources are active elements.

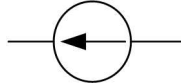
Circuit Element	Symbol	Schematic
Resistor	$R$	 or 
Inductor	$L$	
Capacitor	$C$	
DC Voltage Source	$V_s$	 or 
DC Current Source	$I_s$	

**Table 2.2:** Common circuit elements and their representation in an electric circuit.

## 2.5 Sign Convention

It is common to think of current as the flow of electrons. However, the standard convention is to take the flow of protons to determine the direction of the current.

In a given circuit, the current direction depends on the polarity of the source voltage. Current always flow from positive (high potential) side to the negative (low potential) side of the source as shown in the schematic diagram of Figure 2.4(a) where  $V_s$  is the source voltage,  $V_L$  is the voltage across the load and  $I$  is the loop current flowing in the clockwise direction.

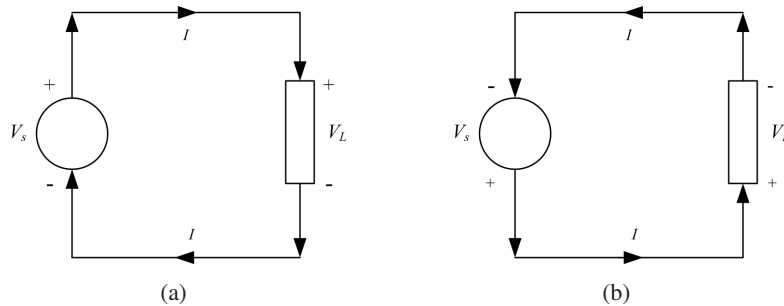

**Figure 2.4:** Effect of reversing the voltage polarity on current direction.

Please observe that the voltage polarity and current direction in a sink is opposite to that of the source.

In Source            current leaves from the positive terminal

In Load (Sink)    current enters from the positive terminal

A reversal in source voltage polarity changes the direction of the current flow and vice versa as depicted in Figures 2.4(a) and 2.4(b).

# Brain power



Plug into The Power of Knowledge Engineering.  
Visit us at [www.skf.com/knowledge](http://www.skf.com/knowledge)

By 2020, wind could provide one-tenth of our planet's electricity needs. Already today, SKF's innovative know-how is crucial to running a large proportion of the world's wind turbines.

Up to 25 % of the generating costs relate to maintenance. These can be reduced dramatically thanks to our systems for on-line condition monitoring and automatic lubrication. We help make it more economical to create cleaner, cheaper energy out of thin air.

By sharing our experience, expertise, and creativity, industries can boost performance beyond expectations. Therefore we need the best employees who can meet this challenge!

The Power of Knowledge Engineering





## 2.6 Passive Circuit Elements

### 2.6.1 Resistor

To describe the resistance of a resistor and hence its characteristics, it is important to define the Ohm's law.

#### Ohm's Law

It is the most fundamental law used in circuit analysis. It provides a simple formula describing the voltage-current relationship in a conducting material.

#### Statement

*The voltage or potential difference across a conducting material is directly proportional to the current flowing through the material.*

Mathematically

$$V \propto I$$

$$V = RI \text{ or } I = \frac{V}{R} \text{ or } R = \frac{V}{I}$$

where the constant of proportionality  $R$  is called the resistance or electrical resistance, measured in ohms ( $\Omega$ ). Graphically, the  $V - I$  relationship for a resistor according to Ohm's law is depicted in Figure 2.5.

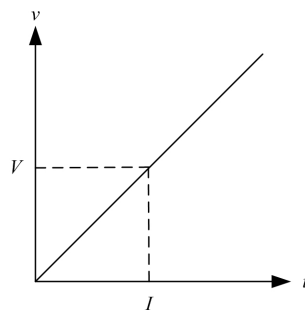

**Figure 2.5:**  $V - I$  relationship for a resistor according to Ohm's law.

At any given point in the above graph, the ratio of voltage to current is always constant.

#### Example

Find  $R$  if the voltage  $V$  and current  $I$  in Figure 2.5 are equal to 10 V and 5 A respectively.

$$V = 10 \text{ V}, I = 5 \text{ A}, R = ?$$

Using Ohm's law

$$V = IR \text{ or } R = \frac{V}{I} = \frac{10}{5}$$

$$\therefore R = 2 \Omega$$

A short circuit between two points represents a zero resistance whereas an open circuit corresponds to an infinite resistance as demonstrated in Figure 2.6.

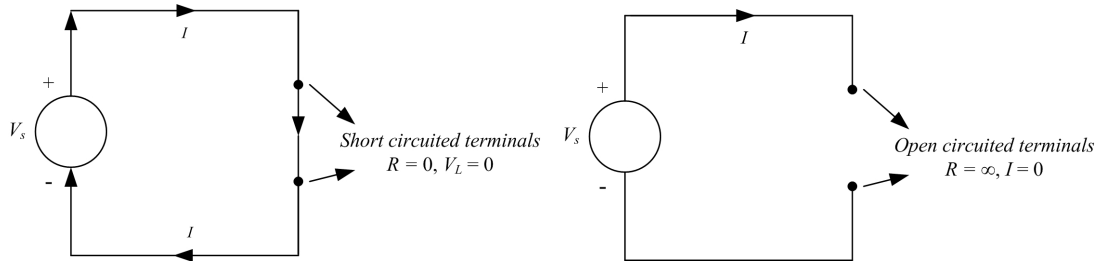

**Figure 2.6:** Short circuit and open circuit resistance characteristics.

Using Ohm’s law,

when  $R = 0$  (short circuit),  $V = 0 \text{ V}$

when  $R = \infty$  (open circuit),  $I = 0 \text{ A}$

### Conductance

Conductance ( $G$ ) is the exact opposite of resistance. In mathematical terms,

$$G = \frac{1}{R}$$

$$\therefore I = \frac{V}{R} = VG$$

where  $G$  is measured in siemens (S) and sometimes also represented by the unit mho ( $\text{U}$ ) (upside-down omega).

### 2.6.2 Capacitor

A capacitor is a passive circuit element that has the capacity to store charge in an electric field. It is widely used in electric circuits in the form of a filter. The  $V - I$  relationship for a capacitor is governed by the following equation

$$i = C \frac{dv}{dt} \text{ or } v = \frac{1}{C} \int_0^t i dt + v(0)$$

where  $C$  is the capacitance measured in Farads (F) and  $v(0)$  is the initial voltage or initial charge stored in the capacitor.

When  $v = V$  (constant DC voltage),  $\frac{dv}{dt} = 0$ , and  $i = 0$ . Hence a capacitor acts as an open circuit to DC.

**Example**

For the circuit diagram shown in Figure 2.7, determine the current,  $I$  flowing through the  $5\ \Omega$  resistance.

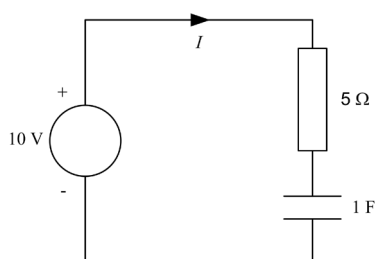

**Figure 2.7**

Since the supply voltage is DC, therefore the capacitor will act as an open circuit. Hence no current can flow through the circuit regardless of the values of capacitor and resistor i.e.

$$I = 0$$

**2.6.3 Inductor**

An inductor is a piece of conducting wire generally wrapped around a core of a ferromagnetic material. Like capacitors, they are employed as filters as well but the most well known application is their use in AC transformers or power supplies that converts AC voltage levels.

In an inductor, the  $V - I$  relationship is given by the following differential equation

$$v = L \frac{di}{dt} \text{ or } i = \frac{1}{L} \int_0^t v dt + i(0)$$

where  $L$  is the inductance in Henrys (H) and  $i(0)$  is the initial current stored in the magnetic field of the inductor.

When  $i = I$  (constant DC current),  $\frac{di}{dt} = 0$ ,  $v = 0$ . Hence an inductor acts as a short circuit to DC. An ideal inductor is just a piece of conducting material with no internal resistance or capacitance. The schematics in Figure 2.8 are equivalent when the supply voltage is DC.

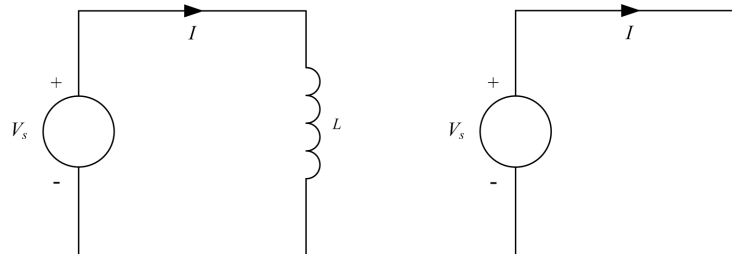

**Figure 2.8:** An ideal inductor can be replaced by a short circuit when the supply voltage is DC.

A summary of the  $V - I$  relationships for the three passive circuit elements is provided in Table 2.3.

Circuit Element	Voltage	Current
Resistor	$V = IR$	$I = \frac{V}{R}$
Inductor	$v = L \frac{di}{dt}$ , $v = 0$ for DC	$i = \frac{1}{L} \int_0^t v dt + i(0)$
Capacitor	$v = \frac{1}{C} \int_0^t i dt + v(0)$	$i = C \frac{dv}{dt}$ , $i = 0$ for DC

**Table 2.3:**  $V - I$  relationships for a resistor, inductor and capacitor.

## 2.7 DC Sources

In general, there are two main types of DC sources

1. Independent (Voltage and Current) Sources
2. Dependent (Voltage and Current) Sources

An independent source produces its own voltage and current through some chemical reaction and does not depend on any other voltage or current variable in the circuit. The output of a dependent source, on the other hand, is subject to a certain parameter (voltage or current) change in a circuit element. Herein, the discussion shall be confined to independent sources only.

### 2.7.1 DC Voltage Source

This can be further subcategorised into ideal and non-ideal sources.

**The Ideal Voltage Source** An ideal voltage source, shown in Figure 2.9(a), has a terminal voltage which is independent of the variations in load. In other words, for an ideal voltage source, the supply current alters with changes in load but the terminal voltage,  $V_L$  always remains constant. This characteristic is depicted in Figure 2.9(b).

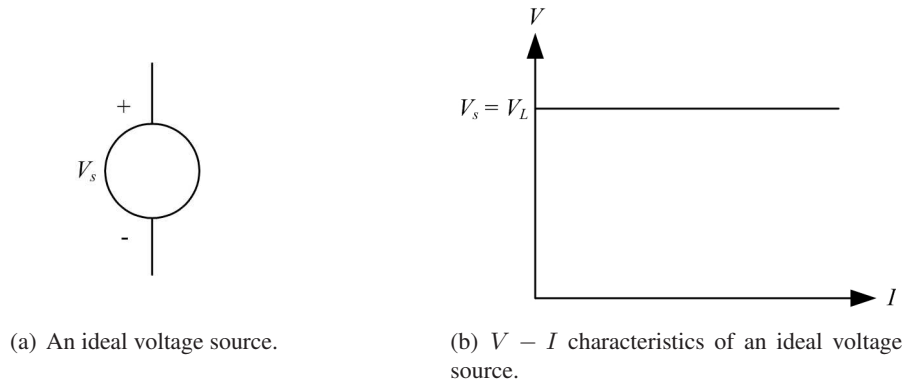

**Figure 2.9:** Schematic and characteristics of an ideal voltage source

**Non-Ideal or Practical Voltage Source** For a practical source, the terminal voltage falls off with an increase in load current. This can be shown graphically in Figure 2.10(a).

This behaviour can be modelled by assigning an internal resistance,  $R_s$ , in series with the source as shown in Figure 2.10(b).

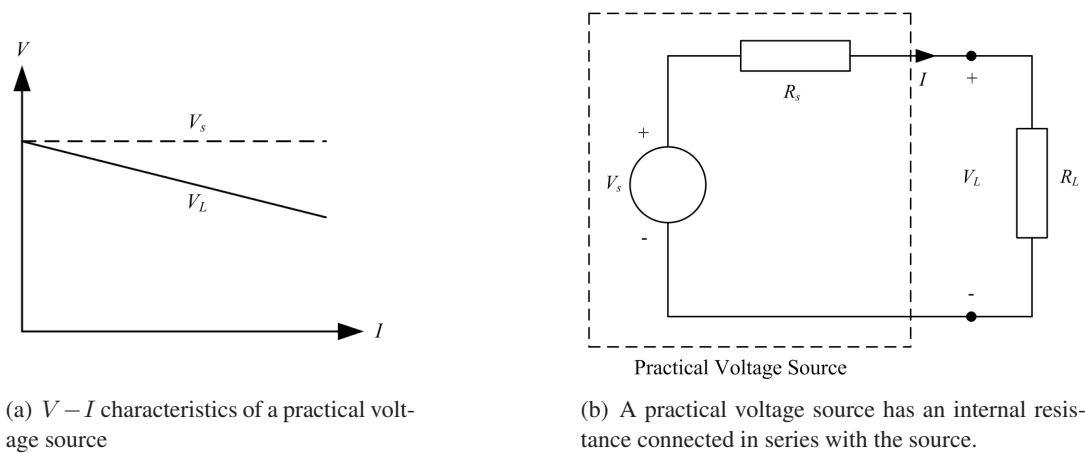

**Figure 2.10:** Characteristics and model of a practical voltage source

where  $R_L$  represents the load resistance.

The characteristic equation of the practical voltage source can be written as

$$V_L = V_s - R_s I$$

For an ideal source,  $R_s = 0$  and therefore  $V_L = V_s$ .

**Example**

The terminal voltage of a battery is 14 V at no load. When the battery is supplying 100 A of current to a load, the terminal voltage drops to 12 V. Calculate the source impedance<sup>1</sup>.

$$V_s = V_{NL} = 14.0 \text{ V when } I = 0 \text{ A (without load)}$$

$$V_L = 12.0 \text{ V when } I = 100 \text{ A (at full load)}$$

$$\therefore V_L = V_s - R_s I$$

$$R_s = \frac{V_s - V_L}{I} = \frac{14 - 12}{100} = \frac{2}{100}$$

$$R_s = 0.02 \Omega$$

<sup>1</sup>Impedance is a more common terminology used in practice instead of resistance. However, impedance is a generic term which could include inductive and capacitive reactances. See Chapter 4 for more details



**> Apply now**

**REDEFINE YOUR FUTURE  
AXA GLOBAL GRADUATE  
PROGRAM 2015**

**redefining / standards**



agence cfr. © Photonstop

### Voltage Regulation

Voltage regulation ( $VR$ ) is an important measure of the quality of a source. It is used to measure the variation in terminal voltage between no load ( $I_L = 0$ , open circuit) and full load ( $I_L = I_{FL}$ ) as shown in Figure 2.11.

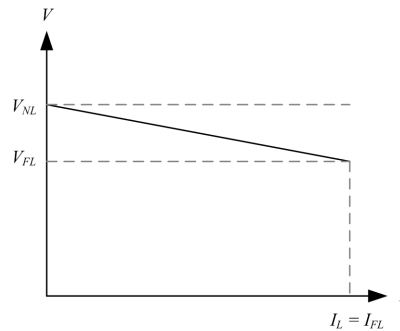

**Figure 2.11:** No load and full load voltages specified on a  $V - I$  characteristic plot of a practical voltage source.

If  $V_{NL}$  and  $V_{FL}$  represents the no load and full load voltages, then the  $VR$  of a source is defined mathematically as

$$VR = \frac{V_{NL} - V_{FL}}{V_{FL}} \times 100\%$$

For an ideal source, there is no internal resistance and hence  $V_{NL} = V_{FL}$  and

$$VR = 0\%$$

Hence, the smaller the regulation, the better the source.

In the previous example,  $V_{NL} = 14.0$  V and  $V_{FL} = 12.0$  V, therefore

$$VR = \frac{14 - 12}{12} \times 100 = 16.67\%$$

### 2.7.2 DC Current Source

A current source, unlike the DC voltage source, is not a physical reality. However, it is useful in deriving equivalent circuit models of semiconductor devices such as a transistor. It can also be subdivided into ideal and non-ideal categories.

**The Ideal Current Source** By definition, an ideal current source, depicted in Figure 2.12(a), produces a current which is independent of the variations in load. In other words the current supplied by an ideal current source does not change with the load voltage.

**Non-Ideal or Practical Current Source** The current delivered by a practical current source falls off with an increase in load or load voltage. This behaviour can be modelled by connecting a resistance in parallel with the ideal current source as shown in Figure 2.12(b) where  $R_s$  is the internal

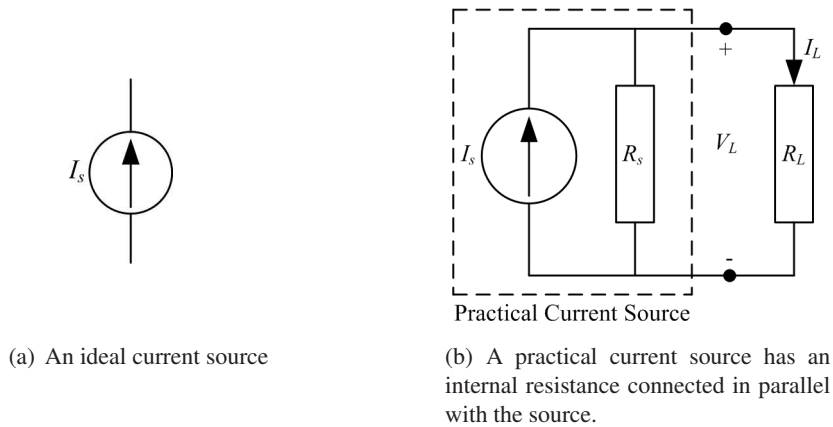

**Figure 2.12:** Ideal and non-ideal current sources.

resistance of the current source and  $R_L$  represents the load.

The characteristic equation of the practical current source can be written as

$$I_L = I_s - \frac{V_L}{R_s}$$

In an ideal current source,  $R_s = \infty$  (open circuit), therefore  $I_L = I_s$ .

## 2.8 Power

Given the magnitudes of  $V$  and  $I$ , power can be evaluated as the product of the two quantities and is measured in Watts (W).

Mathematically

$$P = VI(\text{W})$$

### Example

If the power dissipated in a circuit element is 100 W and a current of 10 A is flowing through it, calculate the voltage across and resistance of the element.

$$P = 100 \text{ W}, I = 10 \text{ A}, V = ?, R = ?$$

$$P = VI$$

$$V = \frac{P}{I} = \frac{100}{10} = 10 \text{ V}$$

$$\text{Also, } R = \frac{V}{I} = \frac{10}{10} = 1 \Omega$$

### Alternate Expressions for Power Using Ohm's Law

Using Ohm's law i.e.  $V = IR$ , two more useful expressions for the power absorbed/delivered can be derived as follows

$$P = VI = (IR)I = I^2R$$

Also,  $I = \frac{V}{R}$

$$\therefore P = VI = V \frac{V}{R} = \frac{V^2}{R}$$

#### Example

A light bulb draws 0.5 A current at an input voltage of 230 V. Determine the resistance of the filament and also the power dissipated.

From Ohm's law

$$R = \frac{V}{I} = \frac{230}{0.5} = 460 \Omega$$

Since a bulb is a purely resistive load, therefore all the power is dissipated in the form of heat. This can be calculated using any of the three power relationships shown above

$$P = VI = 230 \times 0.5 = 115 \text{ W}$$

$$P = I^2R = (0.5)^2 \times 460 = 115 \text{ W}$$

$$P = \frac{V^2}{R} = \frac{(230)^2}{460} = 115 \text{ W}$$

## LIGS University

### based in Hawaii, USA

is currently enrolling in the  
Interactive Online **BBA, MBA, MSc,**  
**DBA and PhD** programs:

- ▶ enroll **by October 31st, 2014** and
- ▶ **save up to 11%** on the tuition!
- ▶ pay in 10 installments / 2 years
- ▶ Interactive **Online education**
- ▶ visit [www.ligsuniversity.com](http://www.ligsuniversity.com) to find out more!

Note: LIGS University is not accredited by any nationally recognized accrediting agency listed by the US Secretary of Education. More info [here](#).





## 2.9 Energy

Energy is defined as the capacity of a physical system to perform work. In the context of electric circuits, energy ( $w$ ) is related to power by the following relationship

$$p = vi = \frac{dw}{dt}$$

i.e. power is the rate of change of energy.

Using Equation 2.2, voltage can also be written in terms of energy as the work done or energy supplied per unit charge ( $q$ ) i.e.

$$v = \frac{dw}{dq}$$

In terms of the three passive circuit elements,  $R$ ,  $L$  and  $C$ , the energy relationships can be derived as follows

### Resistor

$$p = vi = i^2R = \frac{v^2}{R}$$

Electrical power or energy supplied to a resistor is completely dissipated as heat. This action is irreversible and is also commonly termed as  $i^2R$  losses.

### Inductor

$$p = vi = Li \frac{di}{dt}$$

Total energy supplied from 0 to  $t$  is

$$w = \int_0^t p dt = L \int_0^t i \frac{di}{dt} dt = L \int i di$$

$$\therefore \boxed{W = \frac{1}{2}LI^2}$$

This energy is stored in the magnetic field of the inductor which can be supplied back to the circuit when the actual source is removed.

**Capacitor**

$$p = vi = Cv \frac{dv}{dt}$$

Total energy supplied from 0 to  $t$  is

$$w = \int_0^t p dt = C \int_0^t v \frac{dv}{dt} dt = C \int v dv$$

$$\therefore \boxed{W = \frac{1}{2} CV^2}$$

This energy is stored in the electric field of the capacitor which is supplied back to the circuit when the actual source is removed.

## TURN TO THE EXPERTS FOR SUBSCRIPTION CONSULTANCY

Subscribe is one of the leading companies in Europe when it comes to innovation and business development within subscription businesses.

We innovate new subscription business models or improve existing ones. We do business reviews of existing subscription businesses and we develop acquisition and retention strategies.

Learn more at [linkedin.com/company/subscribe](https://www.linkedin.com/company/subscribe) or contact Managing Director Morten Suhr Hansen at [mha@subscribe.dk](mailto:mha@subscribe.dk)

**SUBSCRIBE** - to the future



## Chapter 3

# Circuit Theorems

### 3.1 Introduction

This chapter outlines the most commonly used laws and theorems that are required to analyse and solve electric circuits. Relationships between various laws and equation writing techniques by inspection are also provided. Several examples are shown demonstrating various aspects of the laws. In addition, situations are presented where it is not possible to directly apply the concepts and potential remedies are provided.

### 3.2 Definitions and Terminologies

In the following, various definitions and terminologies frequently used in circuit analysis are outlined. The reader will regularly encounter these terminologies and hence it is important to comprehend those at this stage.

- **Electric Network** A connection of various circuit elements can be termed as an *electric network*. The circuit diagram shown in Figure 3.1 is an electric network.
- **Electric Circuit** A connection of various circuit elements of an electric network forming a closed path is called an *electric circuit*. The closed path is commonly termed as either *loop* or *mesh*.

In Figure 3.1, meshes BDEB, ABCA and BCDB are electric circuits because they form a closed path. In general, all circuits are networks but not all networks are circuits.

- **Node** A connection point of several circuit elements is termed as a *node*. For instance, A, B, C, D and E are five nodes in the electric network of Figure 3.1. Please note that there is no element connected between nodes A and C and therefore can be regarded as a single node.
- **Branch** The path in an electric network between two nodes is called a *branch*. AB, BE, BD, BC, CD and DE are six branches in the network of Figure 3.1.

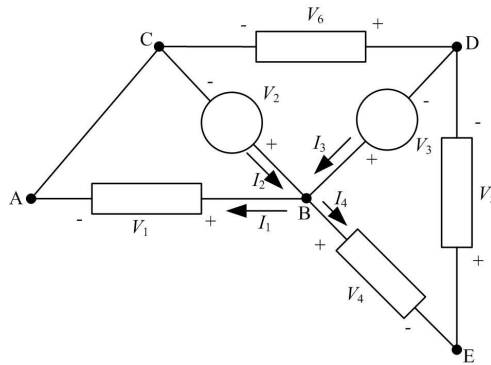

Figure 3.1: An electric network showing nodes, branches, elements and loops.

### 3.3 Kirchoff’s Laws

Arguably the most common and useful set of laws for solving electric circuits are the Kirchoff’s voltage and current laws. Several other useful relationships can be derived based on these laws.

#### 3.3.1 Kirchoff’s Voltage Law (KVL)

*“The sum of all the voltages (rises and drops) around a closed loop is equal to zero.”*

In other words, the algebraic sum of all voltage rises is equal to the algebraic sum of all the voltage drops around a closed loop. In Figure 3.1, consider mesh BEDB, then according to KVL

$$V_3 = V_4 + V_5$$

“I studied English for 16 years but...  
...I finally learned to speak it in just six lessons”  
Jane, Chinese architect

ENGLISH OUT THERE

Click to hear me talking before and after my unique course download



**Example**

In each of the circuit diagrams in Figure 3.2, write the mesh equations using KVL.

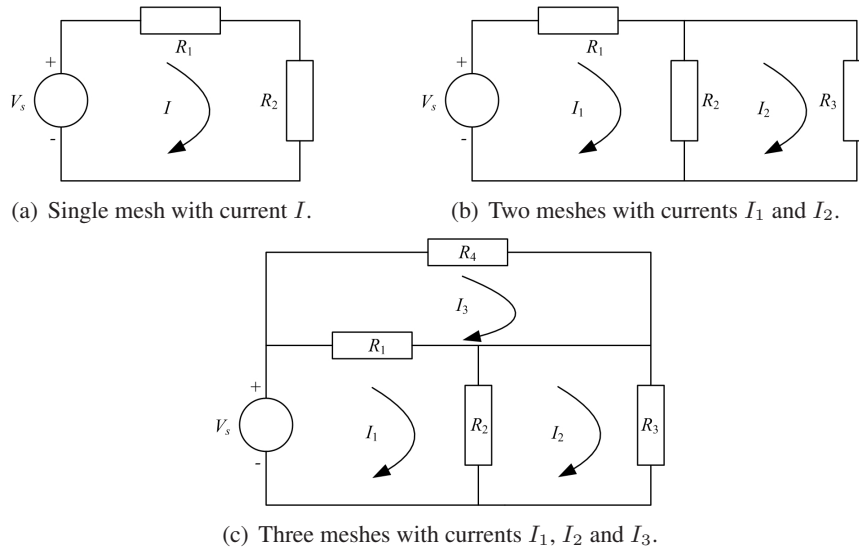

**Figure 3.2:** Circuit diagrams to demonstrate the application of KVL in the above example.

Figure 3.2(a) contains a single loop hence a single current,  $I$  is flowing around it. Therefore a single equation will result as given below

$$V_s = IR_1 + IR_2 \tag{3.1}$$

If  $V_s$ ,  $R_1$  and  $R_2$  are known, then  $I$  can be found.

Figure 3.2(b) contains two meshes with currents  $I_1$  and  $I_2$  hence there will be two equations as shown below. Note that the branch containing  $R_2$  is common to both meshes with currents  $I_1$  and  $I_2$  flowing in opposite directions.

*Left loop*

$$\begin{aligned} V_s &= I_1R_1 + (I_1 - I_2)R_2 \\ V_s &= (R_1 + R_2)I_1 - R_2I_2 \end{aligned} \tag{3.2}$$

*Right loop*

$$\begin{aligned} 0 &= (I_2 - I_1)R_2 + I_2R_3 \\ 0 &= -R_2I_1 + (R_2 + R_3)I_2 \end{aligned} \tag{3.3}$$

Given  $V_s$ ,  $R_1$ ,  $R_2$  &  $R_3$ , Equations 3.2 and 3.3 can be solved simultaneously to evaluate  $I_1$  and  $I_2$ .

For the circuit diagram of Figure 3.2(c), three equations need to be written as follows. Also note that there is no circuit element shared between loops 2 and 3 hence  $I_2$  and  $I_3$  are independent of each other.

*Left bottom loop*

$$\begin{aligned} V_s &= (I_1 - I_3)R_1 + (I_1 - I_2)R_2 \\ V_s &= (R_1 + R_2)I_1 - R_2I_2 - R_1I_3 \end{aligned} \quad (3.4)$$

*Right bottom loop*

$$\begin{aligned} 0 &= (I_2 - I_1)R_2 + I_2R_3 \\ 0 &= -R_2I_1 + (R_2 + R_3)I_2 \end{aligned} \quad (3.5)$$

*Upper loop*

$$\begin{aligned} 0 &= (I_3 - I_1)R_1 + I_3R_4 \\ 0 &= -R_1I_1 + (R_1 + R_4)I_3 \end{aligned} \quad (3.6)$$

If  $V_s$  and resistors' values are known, the mesh currents can be evaluated by solving<sup>1</sup> Equations 3.4, 3.5 and 3.6 simultaneously.

### Resistors in Series

Consider Figure 3.3 with one voltage source and two resistors connected in series to form a single mesh with current  $I$ .

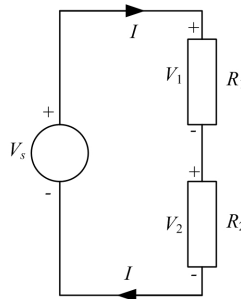

**Figure 3.3:** Series combination of two resistors.

According to KVL

$$V_s = V_1 + V_2$$

Using Ohm's law ( $V = IR$ ) from Chapter 2,

$$\begin{aligned} IR_{eq} &= IR_1 + IR_2 \\ R_{eq} &= R_1 + R_2 \end{aligned} \quad (3.7)$$

<sup>1</sup>When there are three or more unknown variables, it may be convenient to use matrix method or Cramer's rule. See Appendix A for a description of Cramer's rule.

where  $R_{eq}$  is the combined or equivalent resistance of the series network. Hence the equivalent resistance of two or more resistors connected in series is given by the algebraic sum of all the resistances. In general, for  $n$  number of serial resistors,  $R_{eq}$  is given by

$$R_{eq} = R_1 + R_2 + R_3 + \cdots + R_n \quad (3.8)$$

### Voltage Divider Rule (VDR)

Voltage divider rule provides a useful formula to determine the voltage across any resistor when two or more resistors are connected in series with a voltage source. In Figure 3.3, the voltage across the individual resistors can be given in terms of the supply voltage and the magnitude of individual resistances as follows

$$V_1 = V_s \frac{R_1}{R_1 + R_2} \quad (3.9)$$

$$V_2 = V_s \frac{R_2}{R_1 + R_2} \quad (3.10)$$

In general, for  $n$  number of resistors connected in series, the voltage across the  $i$ th resistor can be specified as

$$V_i = V_s \frac{R_i}{R_1 + R_2 + \cdots + R_i + \cdots + R_n} \quad (3.11)$$

**wethrive.net**

**How to retain your top staff**

**FIND OUT NOW FOR FREE**

**DO YOU WANT TO KNOW:**

- What your staff really want?
- The top issues troubling them?
- How to make staff assessments work for you & them, painlessly?

**Get your free trial**

Because happy staff get more done

### 3.3.2 Kirchoff's Current Law (KCL)

*“The algebraic sum of all the currents entering or leaving a node in an electric circuit is equal to zero.”*

In other words, the sum of currents entering is equal to the sum of currents leaving the node in an electric circuit. Consider node B in Figure 3.1, then according to KCL

$$I_1 + I_4 = I_2 + I_3$$

#### Example

For the circuit diagrams depicted in Figure 3.4, write the nodal equations.

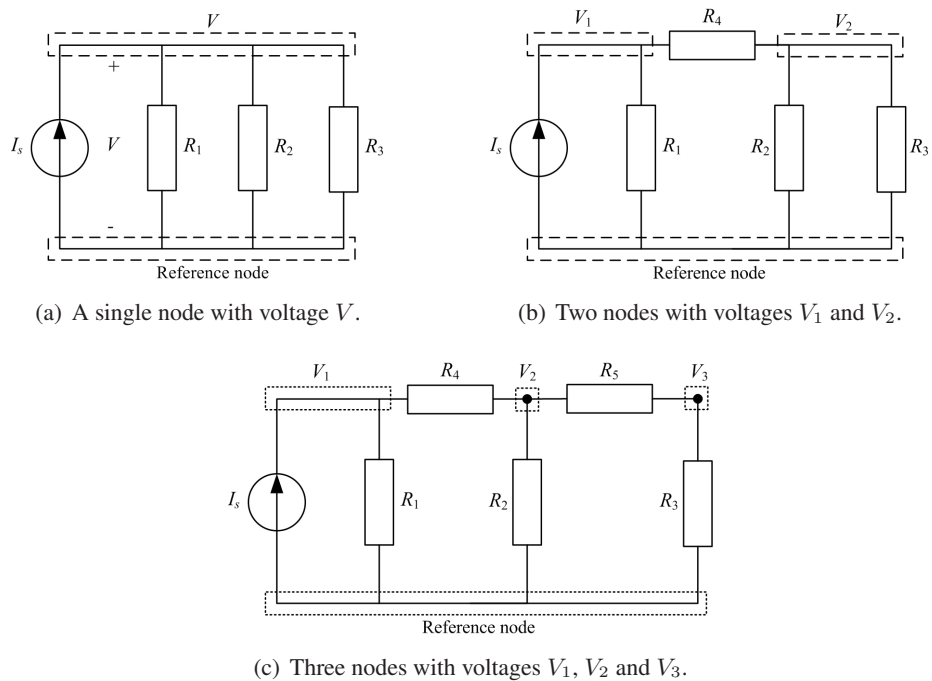

**Figure 3.4:** Circuit diagrams to demonstrate the application of KCL in the above example.

Figure 3.4(a) contains just one node excluding the reference, hence one equation is required.

$$I_s = \frac{V}{R_1} + \frac{V}{R_2} + \frac{V}{R_3} \tag{3.12}$$

If  $I_s$ ,  $R_1$ ,  $R_2$  and  $R_3$  are known in Equation 3.12,  $V$  can be determined.

In Figure 3.4(b), two equations are written for the two nodes labelled  $V_1$  and  $V_2$ .

*Left node*

$$\begin{aligned} I_s &= \frac{V_1}{R_1} + \frac{V_1 - V_2}{R_4} \\ I_s &= \left( \frac{1}{R_1} + \frac{1}{R_4} \right) V_1 - \frac{1}{R_4} V_2 \end{aligned} \quad (3.13)$$

*Right node*

$$\begin{aligned} 0 &= \frac{V_2 - V_1}{R_4} + \frac{V_2}{R_2} + \frac{V_2}{R_3} \\ 0 &= -\frac{1}{R_4} V_1 + \left( \frac{1}{R_2} + \frac{1}{R_3} + \frac{1}{R_4} \right) V_2 \end{aligned} \quad (3.14)$$

Equations 3.13 and 3.14 can be simultaneously solved to determine the node voltages provided the resistors' values and  $I_s$  are known.

Figure 3.4(c) contains 3 nodes hence three equations are required to solve for node voltages  $V_1$ ,  $V_2$  and  $V_3$ .

*Left node*

$$\begin{aligned} I_s &= \frac{V_1}{R_1} + \frac{V_1 - V_2}{R_4} \\ I_s &= \left( \frac{1}{R_1} + \frac{1}{R_4} \right) V_1 - \frac{1}{R_4} V_2 \end{aligned} \quad (3.15)$$

*Middle node*

$$\begin{aligned} 0 &= \frac{V_2 - V_1}{R_4} + \frac{V_2}{R_2} + \frac{V_2 - V_3}{R_5} \\ 0 &= -\frac{1}{R_4} V_1 + \left( \frac{1}{R_2} + \frac{1}{R_4} + \frac{1}{R_5} \right) V_2 - \frac{1}{R_5} V_3 \end{aligned} \quad (3.16)$$

*Right node*

$$\begin{aligned} 0 &= \frac{V_3 - V_2}{R_5} + \frac{V_3}{R_3} \\ 0 &= -\frac{1}{R_5} V_2 + \left( \frac{1}{R_3} + \frac{1}{R_5} \right) V_3 \end{aligned} \quad (3.17)$$

Node voltages  $V_1$ ,  $V_2$  and  $V_3$  can be evaluated by simultaneously solving Equations 3.15, 3.16 and 3.17 using Cramer's rule.

### Resistors in Parallel

Consider Figure 3.5 with a single current source and two resistors connected in parallel. All parallel circuit elements have the same voltage,  $V$  across them i.e.  $V_1 = V_2 = V$

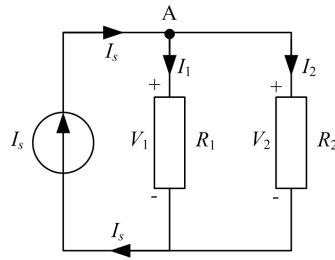

**Figure 3.5:** Parallel connection of resistors.

Applying KCL at node A

$$I_s = I_1 + I_2$$

Using Ohm's law ( $I = \frac{V}{R}$ )

$$\frac{V}{R_{eq}} = \frac{V}{R_1} + \frac{V}{R_2}$$

$$\boxed{\frac{1}{R_{eq}} = \frac{1}{R_1} + \frac{1}{R_2}} \quad (3.18)$$

where  $R_{eq}$  is the equivalent resistance of the parallel<sup>2</sup> network of resistors. For  $n$  number of resistors connected in parallel, the combined resistance is given by

$$\boxed{\frac{1}{R_{eq}} = \frac{1}{R_1} + \frac{1}{R_2} + \frac{1}{R_3} + \cdots + \frac{1}{R_n}} \quad (3.19)$$

or in terms of conductance,  $G$

$$\boxed{G_{eq} = G_1 + G_2 + G_3 + \cdots + G_n} \quad (3.20)$$

<sup>2</sup>To illustrate a parallel relationship between two or more resistors, the symbol ' $||$ ' is occasionally used.

### Current Divider Rule (CDR)

Current divider rule provides a useful relationship for determining the current through individual circuit elements that are connected in *parallel*. For the circuit depicted in Figure 3.5, the current through each resistor can be evaluated using the following formulae

$$I_1 = I_s \frac{R_2}{R_1 + R_2} \quad (3.21)$$

$$I_2 = I_s \frac{R_1}{R_1 + R_2} \quad (3.22)$$

Notice the difference between VDR and CDR (for two resistors) in terms of the resistor value in the numerators. In order to generalise CDR for  $n$  number of resistors, the conductance parameter is used. Hence to find the current through *ith* of  $n$  resistors connected in parallel, the following relationship can be used

$$I_i = I_s \frac{G_i}{G_1 + G_2 + \cdots + G_i + \cdots + G_n} \quad (3.23)$$

The above equation has the same form as the generalised VDR with  $R$  replaced by  $G$  and voltages replaced by current variables.

## 3.4 Electric Circuits Analysis

The KVL, KCL and Ohm's law are the primary tools to analyse DC electric circuits. The term *nodal analysis* is generally used when analysing an electric circuit with KCL whereas loop or *mesh analysis* is designated for problem solving using KVL.

The mesh and nodal analysis methods outlined below are quite systematic and usually provides the solution to a given problem. However, they are fairly computational and an alternative straightforward solution may exist using circuit reduction techniques such as series/parallel combination of resistors and/or VDR/CDR methods.

### 3.4.1 Mesh Analysis

The mesh analysis technique consists of the following steps

1. Transform all currents sources to voltage sources, if possible (see Section 3.8).
2. Identify and assign a current to each mesh of the network (preferably in the same direction).
3. Write mesh equations using KVL and simplify them.
4. Solve the simultaneous system of equations.
5. Number of equations is equal to number of meshes in the network.

### 3.4.2 Nodal Analysis

The following steps describe the nodal analysis method

1. Transform all voltage sources to current sources, if possible (see Section 3.8).
2. Identify and assign an arbitrary voltage to each node including the reference node in the network assuming all currents leaving the node. The reference node is normally assumed to be at zero potential.
3. Write nodal equations using KCL and simplify them.
4. Solve the simultaneous system of equations.
5. Number of equations is  $N - 1$  where  $N$  is the number of nodes in the network including the reference node.

#### Example

Calculate the current supplied by the 30 V source and the current through each resistor in the circuit diagram shown in Figure 3.6 using (1) nodal analysis, (2) mesh analysis and (3) circuit reduction techniques, where  $R_1 = R_2 = R_3 = R_4 = 10 \Omega$ .

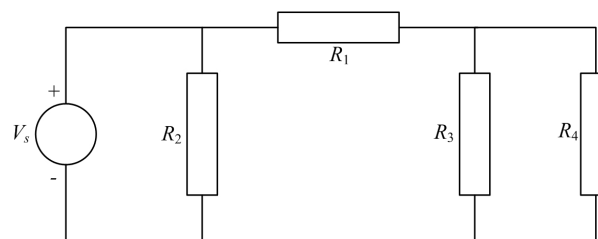

Figure 3.6

#### Solution 1. Nodal Analysis

Source transformation is not possible for this circuit since it requires a resistor in series with the voltage source (see Section 3.8). Three nodes are identified in the above circuit diagram and labelled as 0, 1 and 2 as illustrated in Figure 3.7 where 0 is the reference node. Specify  $V_1$  and  $V_2$  as voltages of nodes 1 and 2 respectively.

The voltage source,  $V_s$  and  $R_2$  are in parallel therefore  $V_1 = V_s = 30 \text{ V}$  is known by inspection.

Applying KCL at node 2 assuming all currents are leaving the node, therefore

$$\begin{aligned} \frac{V_2 - V_1}{R_1} + \frac{V_2}{R_3} + \frac{V_2}{R_4} &= 0 \\ \frac{V_2 - 30}{10} + \frac{V_2}{10} + \frac{V_2}{10} &= 0 \\ V_2 - 30 + V_2 + V_2 &= 0 \\ V_2 &= 10 \text{ V} \end{aligned}$$

The required currents can now be found using Ohm's law.

$$I_{R_1} = \frac{V_1 - V_2}{R_1} = \frac{30 - 10}{10} = 2 \text{ A}$$

$$I_{R_2} = \frac{V_1}{R_2} = \frac{30}{10} = 3 \text{ A}$$

$$I_{R_3} = \frac{V_2}{R_3} = \frac{10}{10} = 1 \text{ A}$$

$$I_{R_4} = \frac{V_2}{R_4} = \frac{10}{10} = 1 \text{ A}$$

The current supplied by the voltage source,  $I_s$  is given by the sum of currents  $I_{R_1}$  and  $I_{R_2}$  i.e.

$$I_s = I_{R_1} + I_{R_2} = 2 + 3 = 5 \text{ A}$$

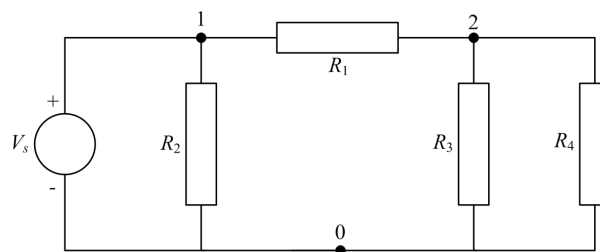
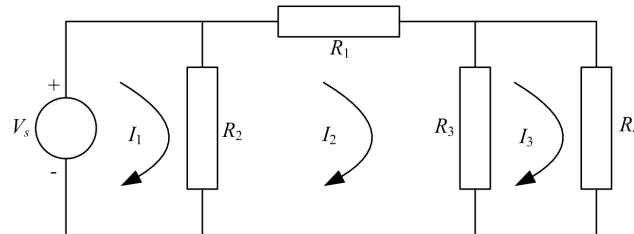

**Figure 3.7:** Circuit diagram showing three nodes labelled as 0, 1, 2 where 0 is the reference node.



**Solution 2. Mesh Analysis**

Three meshes can be identified with currents  $I_1$ ,  $I_2$  and  $I_3$  as illustrated in Figure 3.8 where all the currents are assumed to be flowing in the clockwise direction.



**Figure 3.8:** For mesh analysis, three loops are highlighted with currents  $I_1$ ,  $I_2$  and  $I_3$ .

Observe the common (shared) circuit elements between the meshes such as  $R_2$  (between meshes 1 and 2) and  $R_3$  (between meshes 2 and 3). The current through  $R_2$ , for instance, will be  $I_1 - I_2$  when considering mesh 1 whilst it will be  $I_2 - I_1$  for mesh 2.

The KVL equations can now be written as follows

$$\begin{aligned} (I_1 - I_2)R_2 &= V_s \\ (I_2 - I_1)R_2 + I_2R_1 + (I_2 - I_3)R_3 &= 0 \\ (I_3 - I_2)R_3 + I_3R_4 &= 0 \end{aligned}$$

Substitute the given values of the resistors and voltage source,

$$I_1 - I_2 = 3 \tag{3.24}$$

$$I_1 - 3I_2 + I_3 = 0 \tag{3.25}$$

$$I_2 - 2I_3 = 0 \tag{3.26}$$

The solution of the above simultaneous equations can be obtained either by substitution or by Cramer’s rule or matrix method. Herein, the Cramer’s rule explained in Appendix A is employed.

$$I_1 = \frac{\begin{vmatrix} 3 & -1 & 0 \\ 0 & -3 & 1 \\ 0 & 1 & -2 \end{vmatrix}}{\begin{vmatrix} 1 & -1 & 0 \\ 1 & -3 & 1 \\ 0 & 1 & -2 \end{vmatrix}} = 5 \text{ A}, \quad I_2 = \frac{\begin{vmatrix} 1 & 3 & 0 \\ 1 & 0 & 1 \\ 0 & 0 & -2 \end{vmatrix}}{\begin{vmatrix} 1 & -1 & 0 \\ 1 & -3 & 1 \\ 0 & 1 & -2 \end{vmatrix}} = 2 \text{ A}, \quad I_3 = \frac{\begin{vmatrix} 1 & -1 & 3 \\ 1 & -3 & 0 \\ 0 & 1 & 0 \end{vmatrix}}{\begin{vmatrix} 1 & -1 & 0 \\ 1 & -3 & 1 \\ 0 & 1 & -2 \end{vmatrix}} = 1 \text{ A}$$

$$\begin{aligned} \therefore I_s = I_1 &= 5 \text{ A}, \\ I_{R_1} = I_2 &= 2 \text{ A}, \\ I_{R_4} = I_3 &= 1 \text{ A}, \\ I_{R_2} = I_1 - I_2 &= 3 \text{ A and} \\ I_{R_3} = I_2 - I_3 &= 1 \text{ A} \end{aligned}$$

**Solution 3. Circuit Reduction Techniques**

Circuit reduction techniques include series/parallel combination and VDR/CDR formulae. From the schematic diagram in Figure 3.6, it is clear that  $R_3$  and  $R_4$  are in parallel, therefore they can be combined and reduced to a single resistor,  $R_5$  using Equation 3.18. Hence

$$R_5 = \frac{R_3 R_4}{R_3 + R_4} = \frac{10 \times 10}{10 + 10} = 5 \Omega$$

$R_5$  is in series with  $R_1$ , therefore the combined resistance  $R_6$  can be calculated by Equation 3.7 which is a simple algebraic sum i.e.

$$R_6 = R_1 + R_5 = 10 + 5 = 15 \Omega$$

The equivalent resistance,  $R_6$ , is now in parallel with  $R_2$  giving a single resistance,  $R_7$  of 6  $\Omega$ . The process at each step is depicted in Figure 3.9.

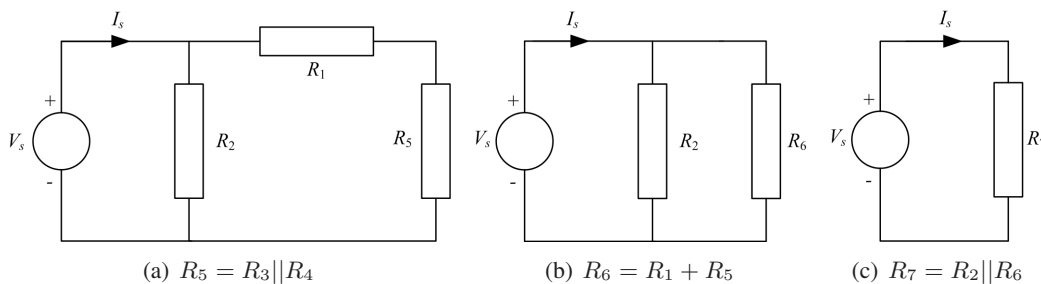

**Figure 3.9:** Circuit reduction using series/parallel combination of resistors.

From Figure 3.9(c), the current,  $I_s$ , supplied by the voltage source can now be calculated using Ohm’s law

$$I_s = \frac{V_s}{R_7} = \frac{30}{6} = 5 \text{ A}$$

In Figure 3.9(b), current through  $R_2$  can be found by applying CDR between  $R_2$  and  $R_6$  i.e.

$$\begin{aligned} I_{R_2} &= I_s \frac{R_6}{R_2 + R_6} = 5 \frac{15}{10 + 15} = 3 \text{ A} \\ \therefore I_{R_6} &= I_s - I_{R_2} = 2 \text{ A} \end{aligned}$$

Since  $R_6$  is a series combination of  $R_1$  and  $R_5$ , therefore

$$I_{R_1} = I_{R_5} = 2 \text{ A}$$

The current  $I_{R_5}$  is the sum of currents through the parallel combination of  $R_3$  and  $R_4$ . Hence CDR can be applied to determine the currents through each resistor. Since  $R_3 = R_4$ , therefore the currents  $I_{R_3}$  and  $I_{R_4}$  are

$$I_{R_3} = I_{R_4} = 1 \text{ A}$$

### 3.5 Superposition Theorem

Superposition theorem is extremely useful for analysing electric circuits that contains two or more active sources. In such cases, the theorem considers each source separately to evaluate the current through or voltage across a component. The resultant is given by the algebraic sum of all currents or voltages caused by each source acting independently. Superposition theorem can be formally stated as follows

*“The current through or voltage across any element in a linear circuit containing several sources is the algebraic sum of the currents or voltages due to each source acting alone, all other sources being removed at that time.”*

Linearity is a necessary condition for the theorem to apply. Fortunately, the  $v, i$  relationship for  $R, L$  and  $C$  are all linear.

This e-book  
is made with  
**SetaPDF**



SETASIGN

PDF components for PHP developers

www.setasign.com



The sources can be removed using the following methodology,

1. Ideal voltage sources are short-circuited
2. Ideal current sources are open-circuited

In general, practical sources are replaced by their internal resistances.

**Example**

Find the voltage  $V_L$  using Superposition theorem in the circuit diagram of Figure 3.10.

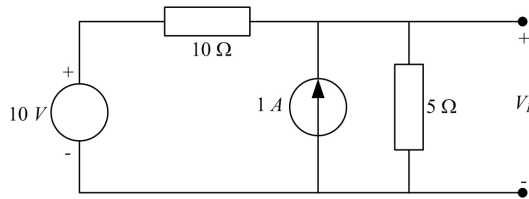
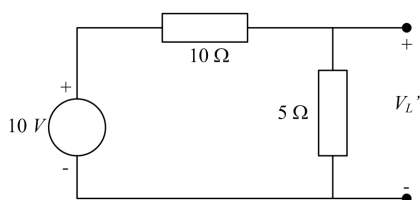

**Figure 3.10:** An electric circuit containing multiple sources.

**Step 1: Suppressing the 1 A current source by replacing it with an open circuit**

This will result in the circuit diagram of Figure 3.11(a). The output voltage, now called  $V'_L$ , is the voltage across the 5 Ω resistance. Since both 10 Ω and 5 Ω are in series, VDR can be applied here

$$\therefore V'_L = 10 \frac{5}{10 + 5} = 3.33 \text{ V}$$



(a) Superposition (step 1) - suppressing the current source.

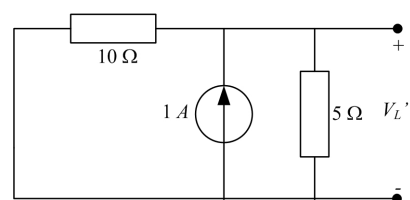

(b) Superposition (step 2) - suppressing the voltage source.

**Figure 3.11:** Application of superposition theorem to Figure 3.10.

**Step 2: Suppressing the 10 V voltage source by replacing it with a short circuit**

The resulting circuit diagram is shown in Figure 3.11(b). The output voltage is now represented by  $V''_L$  and has the same polarity as  $V_L$ . It is obvious that both the resistors are in parallel and therefore CDR can be applied to determine the current flowing through 5 Ω resistor.

$$I_{5\Omega} = 1 \frac{10}{10 + 5} = 0.67 \text{ A}$$

$$\therefore V''_L = I_{5\Omega} \times 5 = 3.33 \text{ V}$$

The total voltage, according to the superposition theorem is then given by the sum of  $V_L'$  and  $V_L''$  i.e.

$$V_L = V_L' + V_L'' = 3.33 + 3.33 = 6.66 \text{ V}$$

### Superposition Theorem - Power Calculation

Although the superposition theorem can be used to find the voltage across and current through a circuit element by adding the responses due to each source acting alone, the power (as a nonlinear relationship) cannot be evaluated until the net voltage or current is found. This is because

$$P = (I_1 + I_2)^2 R \neq I_1^2 R + I_2^2 R$$

$$\text{or } P = \frac{(V_1 + V_2)^2}{R} \neq \frac{V_1^2}{R} + \frac{V_2^2}{R}$$

## 3.6 Thévenin's Theorem

Thévenin's theorem provides a useful tool when solving complex and large electric circuits by reducing them to a single voltage source in series with a resistor. It is particularly advantageous where a single resistor or load in a circuit is subject to change.

Formally, the Thévenin's theorem can be stated as

*“Any two-terminal linear electric circuit consisting of resistors and sources, can be replaced by an equivalent circuit containing a single voltage source in series with a resistor connected across the load.”*

In the circuit diagrams shown in Figure 3.12, the current  $I_L$  through the load resistance  $R_L$  is the same. Hence the circuits are equivalent as far as the load resistor  $R_L$  is concerned.

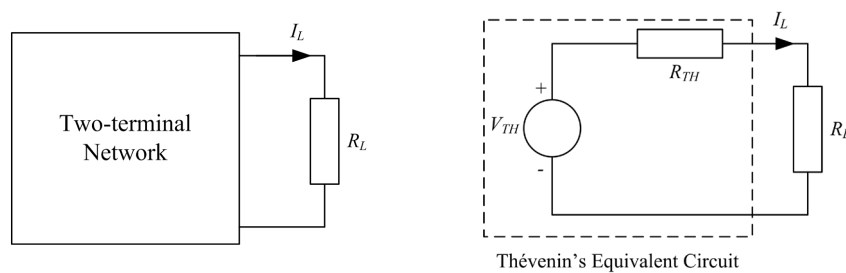

**Figure 3.12:** Illustration of Thévenin's theorem.

The following steps outline the procedure to simplify an electric circuit using Thévenin's theorem where  $V_{TH}$  and  $R_{TH}$  are the Thévenin's voltage and Thévenin's resistance respectively.

1. Remove the load resistance  $R_L$ .
2.  $V_{TH}$  is the open circuit (OC) voltage across the load terminals and

- $R_{TH}$  is the resistance across the load terminals with all sources replaced by their internal resistances.

Alternatively, measure the OC voltage across, and the short circuit (SC) current through the load terminals. Then

$$V_{TH} = V_{oc} \text{ and } R_{TH} = \frac{V_{oc}}{I_{sc}} \tag{3.27}$$

**Example**

Use Thévenin's theorem to find the current through the  $5\ \Omega$  resistance in the circuit diagram of Figure 3.13.

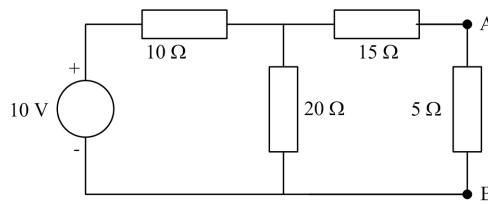

**Figure 3.13**

To evaluate  $R_{TH}$ , remove the load resistance of  $5\ \Omega$  and replace the  $10\ \text{V}$  voltage source by its internal resistance as depicted in Figure 3.14(a).

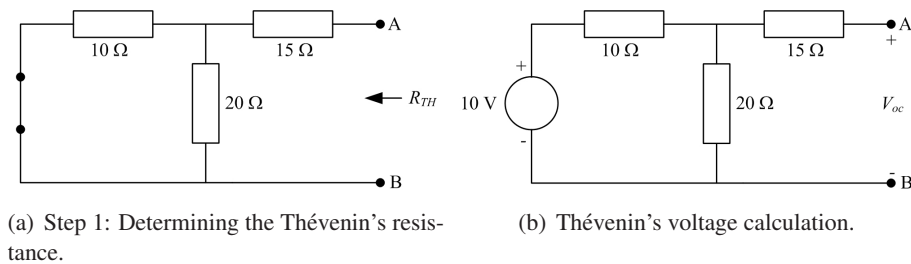

**Figure 3.14:** Determination of Thévenin's voltage,  $V_{TH}$  and Thévenin's resistance,  $R_{TH}$ .

$R_{TH}$  is then given by

$$R_{TH} = (10 || 20) + 15 = \frac{10 \times 20}{10 + 20} + 15 = 21.67\ \Omega$$

To determine  $V_{TH}$  or  $V_{oc}$  across the OC load terminals, note in Figure 3.14(b) that the voltage across the  $20\ \Omega$  resistance is the same as  $V_{oc}$  since the right loop is open and no voltage drop occurs across the  $15\ \Omega$  resistance ( $I_{15\Omega} = 0$ ).

The  $10\ \Omega$  and  $20\ \Omega$  resistors are in series therefore VDR can be employed to determine  $V_{oc}$

$$V_{TH} = V_{oc} = 10 \frac{20}{10 + 20} = 6.67\ \text{V}$$

The Thévenin's equivalent circuit can now be drawn as shown in Figure 3.15. The load resistance of  $5\ \Omega$  is inserted back between the terminals A and B and the load current can be found as follows

$$I_{5\Omega} = \frac{V_{TH}}{R_{TH} + R_L} = \frac{6.67}{21.67 + 5} = 0.25\ \text{A}$$

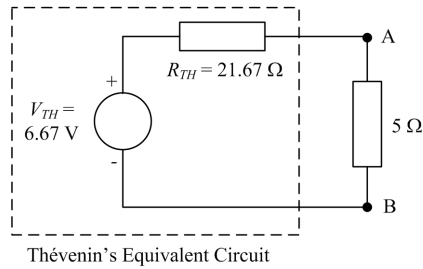

**Figure 3.15:** Thévenin's equivalent circuit for Figure 3.13 across the  $5\ \Omega$  load resistance.



Discover the truth at [www.deloitte.ca/careers](http://www.deloitte.ca/careers)

**Deloitte.**

© Deloitte & Touche LLP and affiliated entities.



### 3.7 Norton's Theorem

Thévenin's equivalent circuit is a practical voltage source. In contrast, Norton's equivalent circuit is a practical current source. This can be formally stated as

*“Any two-terminal, linear circuit, of resistors and sources, can be replaced by a single current source in parallel with a resistor.”*

To determine Norton's equivalent circuit, Norton current,  $I_N$ , and Norton resistance,  $R_N$ , are required. The following steps outline the procedure required.

1. Remove the load resistance,  $R_L$ .
2.  $I_N$  is the SC current through the load terminals and
3.  $R_N$  is the resistance across the load terminals with all sources replaced by their internal resistances. Clearly  $R_N = R_{TH}$ .

#### Example

For the circuit diagram depicted in Figure 3.13, use Norton's theorem to determine the current through the  $5\ \Omega$  resistance.

As mentioned above, The Norton's resistance is the same as the Thévenin's resistance, i.e.

$$R_N = 21.67\ \Omega$$

To find Norton's current, the terminals A and B in Figure 3.14(b) are short circuited. Then the current through the short circuited terminals is the Norton current,  $I_N$  or  $I_{sc}$ .

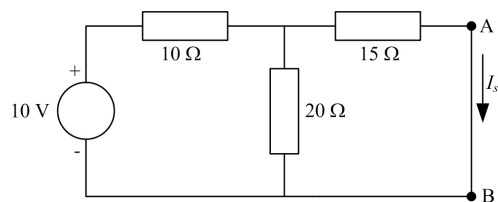

**Figure 3.16**

There are a number of ways to solve the above circuit such as KVL, KCL, however, circuit reduction techniques have been chosen here.

Firstly, the total current supplied by the voltage source can be found by adding the resistances using series/parallel combination.

$$R_{eq} = (15 || 20) + 10 = \frac{15 \times 20}{15 + 20} + 10 = 18.57\ \Omega$$

$$\therefore I_s = \frac{V_s}{R_{eq}} = \frac{10}{18.57} = 0.54\ \text{A}$$

Since  $I_s = I_{10\Omega}$ ,  $I_{sc}$  can be found by employing CDR between the  $15\ \Omega$  and  $20\ \Omega$  resistances i.e.

$$I_{sc} = I_s \frac{20}{15 + 20} = 0.54 \frac{20}{35} = 0.31\ \text{A}$$

The Norton's equivalent circuit can be drawn as shown in Figure 3.17.

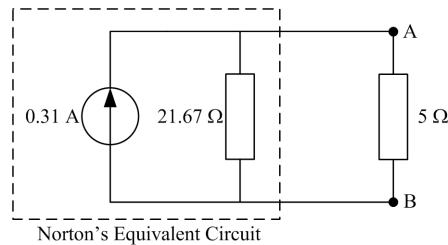

**Figure 3.17:** Norton's equivalent circuit for Figure 3.13 across the  $5\ \Omega$  load.

The current through the  $5\ \Omega$  resistance can be determined by the application of CDR between  $R_L$  and  $R_N$ , thus

$$I_{5\Omega} = 0.31 \frac{21.67}{21.67 + 5} = 0.25\ \text{A}$$

which also tallies with the result when Thévenin's theorem was employed.

### 3.8 Source Transformation

In an electric circuit, it is often convenient to have a voltage source rather than a current source (e.g. in mesh analysis) or vice versa. This is made possible using source transformations. It should be noted that only practical voltage and current sources can be transformed. In other words, a Thévenin's equivalent circuit is transformed into a Norton's one or vice versa. The parameters used in the source transformation are given as follows.

Thévenin parameters:  $V_{TH}, R_{TH} \implies R_N = R_{TH}, I_N = \frac{V_{TH}}{R_{TH}}$

Norton parameters:  $I_N, R_N \implies R_{TH} = R_N, V_{TH} = R_N I_N$

Any load resistance,  $R_L$  will have the same voltage across, and current through it when connected across the terminals of either source.

#### Example

In Figure 3.13, use repeated source transformation to determine the current through the  $5\ \Omega$  resistance.

Noting that the voltage source and the  $10\ \Omega$  resistor are in series, transform the combination into a current source in parallel with the  $10\ \Omega$  resistor. The magnitude of the current source is calculated as follows

$$I = \frac{V}{R} = \frac{10}{10} = 1 \text{ A}$$

The resulting schematic is depicted in Figure 3.18(a). Now the 10 Ω and 20 Ω resistors are in parallel which can be combined together to form a single resistance of 6.67 Ω (see Figure 3.18(b)). This resistance will be in parallel with the 1 A current source that can be transformed back to a voltage source in series with the 6.67 Ω resistance resulting in single loop as shown in Figure 3.18(c). KVL can be applied to determine the loop current which is the same current flowing through the 5 Ω resistor. Hence

$$I_{5\Omega} = \frac{6.67}{6.67 + 15 + 5} = 0.25 \text{ A}$$

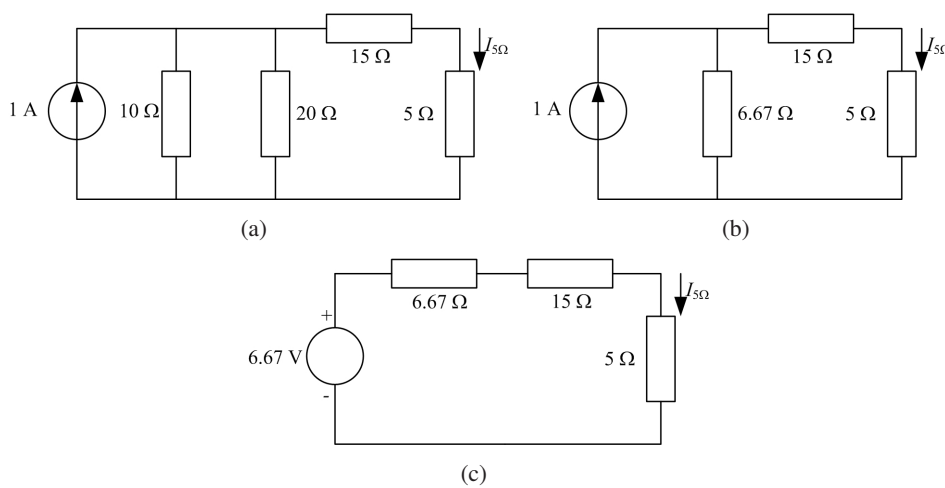

Figure 3.18: Repeated source transformation of Figure 3.18

© 2013 Accenture. All rights reserved.

be > your degree

Bring your talent and passion to a global organization at the forefront of business, technology and innovation. Discover how great you can be.

Visit [accenture.com/bookboon](http://accenture.com/bookboon)

Be greater than.  
consulting | technology | outsourcing

accenture  
High performance. Delivered.



### 3.9 Maximum Power Transfer Theorem

As discussed in the section on Thévenin's theorem, any DC network of sources and resistances can be replaced by a single voltage source in series with a resistance connected across the load (see Figure 3.12). The maximum power transfer theorem states that the power delivered to the load is maximum when the load resistance,  $R_L$  is equal to the internal (source) resistance,  $R_s$  of the DC power supply. In other words, it can be said that the load resistance must match the Thévenin's resistance for maximum power transfer to take place i.e.,

$$(R_s = R_{TH}) = R_L$$

When this occurs, the voltage across the load resistance will be  $\frac{V_s}{2}$  and the power delivered to the load is given by

$$\begin{aligned} P &= V_L I_L \\ &= I_L^2 R_L \\ P &= \frac{V_s^2}{(R_s + R_L)^2} R_L \end{aligned}$$

The above equation is plotted in Figure 3.19 which clearly demonstrates maximum power delivered when  $R_s = R_L$ . Under this condition, the maximum power will be

$$P_{max} = \frac{V_s^2}{4R_s} \quad (3.28)$$

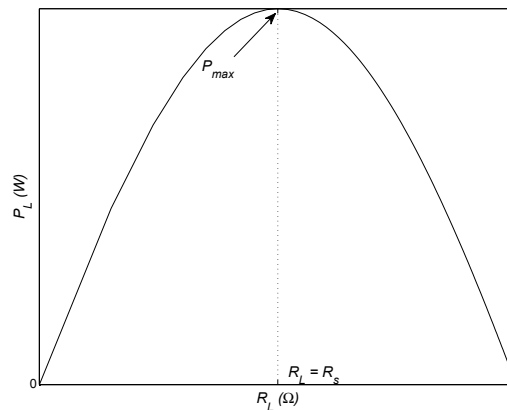

**Figure 3.19:** Illustration of maximum power transfer theorem.

### 3.10 Additional Common Circuit Configurations

In addition to the examples described in the previous sections, there are certain situations where direct application of the circuit rules may not be possible. In this section, two such configurations and their solutions are described.

### 3.10.1 Supernode

A *supernode* exists when an ideal voltage source appears between any two nodes of an electric circuit. The usual way to solve this is to write KCL equations for both nodes and simply add them together into one equation ignoring the voltage source in question. However, this would mean one less equation than the number of variables (node voltages) present in the circuit. A constraint equation can be easily specified given by the magnitude of the ideal voltage source present between the nodes and the respective node voltages. The following example will help clarify this scenario.

#### Example

Determine the voltage across the 1 A current source in the circuit diagram of Figure 3.20 using nodal analysis.

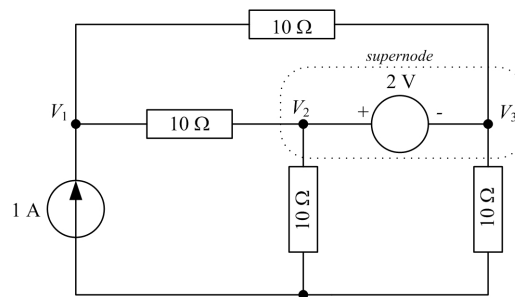

**Figure 3.20:** Illustration of a supernode.

A simple inspection of the circuit diagram reveals the existence of three nodes excluding the reference and are labelled as  $V_1$ ,  $V_2$  and  $V_3$  as their respective node voltages. The presence of an ideal voltage source between nodes 2 and 3 creates a *supernode* and a constraint equation is necessary.

As mentioned, nodal analysis is carried out as normal and the nodal equations of nodes 2 and 3 will be added together.

*Node 1*

$$1 = \frac{V_1 - V_2}{10} + \frac{V_1 - V_3}{10}$$

$$10 = 2V_1 - V_2 - V_3 \tag{3.29}$$

*Supernode*

$$0 = \left( \frac{V_2 - V_1}{10} + \frac{V_2}{10} \right) + \left( \frac{V_3}{10} + \frac{V_3 - V_1}{10} \right)$$

$$0 = -V_1 + V_2 + V_3 \tag{3.30}$$

Since there are three variables and two equations, therefore another equation is needed. This can be written as the constraint equation between nodes 2 and 3 as follows

*Constraint Equation*

$$V_2 - V_3 = 2 \tag{3.31}$$

Equations 3.29, 3.30 and 3.31 can be solved simultaneously to determine the node voltages  $V_1$ ,  $V_2$  and  $V_3$ . Herein, the voltage,  $V_1$ , across the current source is required only. Hence by using Cramer's rule

$$V_1 = \frac{\Delta_1}{\Delta} = \frac{\begin{vmatrix} 10 & -1 & -1 \\ 0 & 1 & 1 \\ 2 & 1 & -1 \end{vmatrix}}{\begin{vmatrix} 2 & -1 & -1 \\ -1 & 1 & 1 \\ 0 & 1 & -1 \end{vmatrix}} = 10 \text{ V,}$$

### 3.10.2 Supermesh

A *supermesh* exists when an ideal current source appears between two meshes of an electric circuit. In such a situation, like supernode, mesh equations are written for the meshes involved and added giving a single equation. Again, there would be one less equation than the number of variables (mesh currents) and hence a constraint equation is needed. This would be based on the magnitude of the ideal current source present between the two meshes and their mesh currents. The following example will help clarify this scenario.

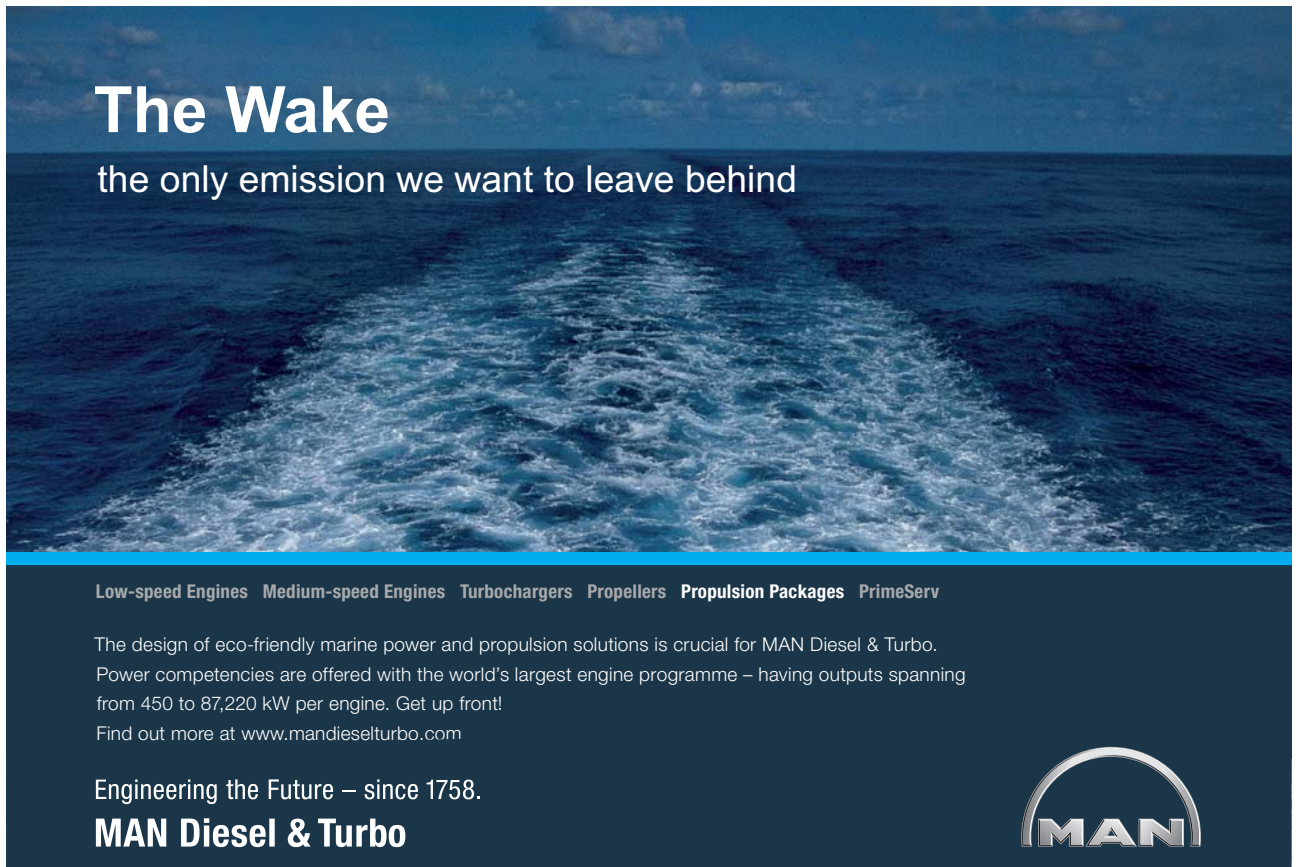

**The Wake**  
the only emission we want to leave behind

Low-speed Engines Medium-speed Engines Turbochargers Propellers Propulsion Packages PrimeServ

The design of eco-friendly marine power and propulsion solutions is crucial for MAN Diesel & Turbo. Power competencies are offered with the world's largest engine programme – having outputs spanning from 450 to 87,220 kW per engine. Get up front!  
Find out more at [www.mandieselturbo.com](http://www.mandieselturbo.com)

Engineering the Future – since 1758.  
**MAN Diesel & Turbo**



**Example**

Determine the current supplied by the 10 V voltage source in the circuit diagram of Figure 3.21.

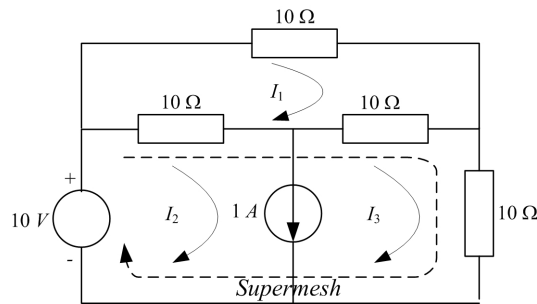

**Figure 3.21:** Illustration of a supermesh.

*Mesh 1*

$$\begin{aligned} 10I_1 + 10(I_1 - I_2) + 10(I_1 - I_3) &= 0 \\ 3I_1 - I_2 - I_3 &= 0 \end{aligned} \tag{3.32}$$

*Supermesh*

$$\begin{aligned} [10(I_2 - I_1)] + [10(I_3 - I_1) + 10I_3] &= 10 \\ -2I_1 + I_2 + 2I_3 &= 1 \end{aligned} \tag{3.33}$$

*Constraint Equation*

$$I_2 - I_3 = 1 \tag{3.34}$$

The current supplied by the 10 V source is  $I_2$ , thus according to Cramer’s rule

$$I_2 = \frac{\Delta_2}{\Delta} = \frac{\begin{vmatrix} 3 & 0 & -1 \\ -2 & 1 & 2 \\ 0 & 1 & -1 \end{vmatrix}}{\begin{vmatrix} 3 & -1 & -1 \\ -2 & 1 & 2 \\ 0 & 1 & -1 \end{vmatrix}} = 1 \text{ A}$$

### 3.11 Mesh and Nodal Analysis by Inspection

It may seem rather cumbersome and demanding (especially for the beginners) to write correct nodal and mesh equations using the methods outlined in Sections 3.4.1 and 3.4.2. Although it is vital that students have a clear understanding of the underlying concepts, nonetheless there are methods devised to write nodal and mesh equations by inspection using *ad hoc* relationships. This provides a useful way to quickly analyse a given circuit to determine a particular current or voltage.

### 3.11.1 Mesh Analysis

To demonstrate writing mesh equations by inspection, consider Figure 3.2(c) which consists of three meshes with currents denoted as  $I_1$ ,  $I_2$  and  $I_3$ . The mesh equations have been derived earlier in Equations 3.4, 3.5 and 3.6 and reproduced below for convenience.

$$V_s = (R_1 + R_2)I_1 - R_2I_2 - R_1I_3 \quad (3.35)$$

$$0 = -R_2I_1 + (R_2 + R_3)I_2 \quad (3.36)$$

$$0 = -R_1I_1 + (R_1 + R_4)I_3 \quad (3.37)$$

In matrix form, the above equations can be written as

$$\begin{bmatrix} V_s \\ 0 \\ 0 \end{bmatrix} = \begin{bmatrix} R_1 + R_2 & -R_2 & -R_1 \\ -R_2 & R_2 + R_3 & 0 \\ -R_1 & 0 & R_1 + R_4 \end{bmatrix} \begin{bmatrix} I_1 \\ I_2 \\ I_3 \end{bmatrix} \quad (3.38)$$

The order of the resistance matrix ( $\mathbf{R}$ ) is the same as number of loops in the circuit. Additionally it has a general structure as outlined below which is independent of the number of equations or meshes.

$$\begin{aligned} R_{ii} &= i^{th} \text{ diagonal entry} \\ &= \text{sum of all resistances in the } i^{th} \text{ mesh.} \end{aligned}$$

$$\begin{aligned} R_{ij} &= \text{off-diagonal entry} \\ &= -[\text{sum of resistances common to meshes } i \text{ and } j]. \end{aligned}$$

$$\mathbf{R} = \mathbf{R}^T \quad \text{i.e. } \mathbf{R} \text{ is a symmetric matrix.}$$

### 3.11.2 Nodal Analysis

The circuit diagram in Figure 3.4(c) can be used to demonstrate the technique to write nodal equations by inspection. The equations for this circuit have been derived earlier and reproduced below for reader's convenience.

$$\begin{aligned} I_s &= \left( \frac{1}{R_1} + \frac{1}{R_4} \right) V_1 - \frac{1}{R_4} V_2 \\ 0 &= -\frac{1}{R_4} V_1 + \left( \frac{1}{R_2} + \frac{1}{R_4} + \frac{1}{R_5} \right) V_2 - \frac{1}{R_5} V_3 \\ 0 &= -\frac{1}{R_5} V_2 + \left( \frac{1}{R_3} + \frac{1}{R_5} \right) V_3 \end{aligned}$$

Noting that  $\frac{1}{R} = G$  (conductance), the above equations can be rewritten as follows

$$I_s = (G_1 + G_4) V_1 - G_4 V_2 \tag{3.39}$$

$$0 = -G_4 V_1 + (G_2 + G_4 + G_5) V_2 - G_5 V_3 \tag{3.40}$$

$$0 = -G_5 V_2 + (G_3 + G_5) V_3 \tag{3.41}$$

In matrix form

$$\begin{bmatrix} I_s \\ 0 \\ 0 \end{bmatrix} = \begin{bmatrix} G_1 + G_4 & -G_4 & 0 \\ -G_4 & G_2 + G_4 + G_5 & -G_5 \\ 0 & -G_5 & G_3 + G_5 \end{bmatrix} \begin{bmatrix} V_1 \\ V_2 \\ V_3 \end{bmatrix} \tag{3.42}$$

The conductance matrix (**G**) has the same order as the number of nodes excluding the reference node. Moreover, it has a general structure as outline below which is independent of the number of nodes in the network.

$G_{ii}$  =  $i^{th}$  diagonal entry  
 = sum of all conductances directly connected to  $i^{th}$  node.

$G_{ij}$  = off-diagonal entry  
 = -[sum of conductances connected between nodes  $i$  and  $j$ ].

$\mathbf{G} = \mathbf{G}^T$  i.e. **G** is a symmetric matrix.

FREE  
 30 days trial!

# SMS from your computer

...Sync'd with your Android phone & number

Go to  
BrowserTexting.com

and start texting from your computer!



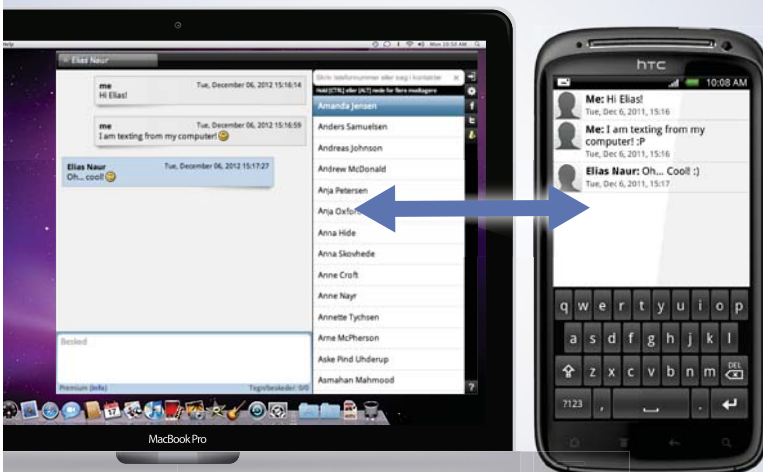

## Chapter 4

# Sinusoids and Phasors

### 4.1 Introduction

In Chapter 3, circuit analysis was carried out with DC excitation voltage or current. Herein, the response to same type of *RLC* circuits is analysed using AC sources. Phasors are introduced as well as the concept of impedance of an electric circuit. The chapter concludes with power relationships in AC circuits and its related theory.

The concept of sinusoidal current and voltage is first introduced as this forms the basis of AC circuit analysis.

### 4.2 Sinusoids

In circuit analysis, the term AC generally refers to a sinusoidal current or voltage signal. Sinusoids or more commonly sine waves are arguably the most important class of waveforms in electrical engineering. A common example is the mains voltage which is sinusoidal in nature. In general, any periodic waveform can be generated using a combination of sinusoidal signals of varying frequencies and amplitudes. The two most important parameters of a sine wave are its amplitude,  $V_m$  and frequency,  $f$  or time period,  $T$ .

Figure 4.1(a) shows a sinusoid and related parameters  $V_m$  and  $T$ . The frequency is then given by the reciprocal of the time period i.e.  $f = \frac{1}{T}$ . Note that two complete cycles (time periods) are plotted which clearly shows the periodic nature of a sine wave.

Peak to peak amplitude is also occasionally used given as two times the peak amplitude. Another parameter that is vital for AC analysis is the phase,  $\phi$  of the sine wave. This is normally measured with respect to a reference waveform as shown in Figure 4.1(b). It is important to point out that sinusoidal generally refers to either sine or cosine waveform where the cosine wave has the same shape but is  $90^\circ$  out of phase with respect to the sine wave.

Mathematically, a sinusoidal signal is given by the general form

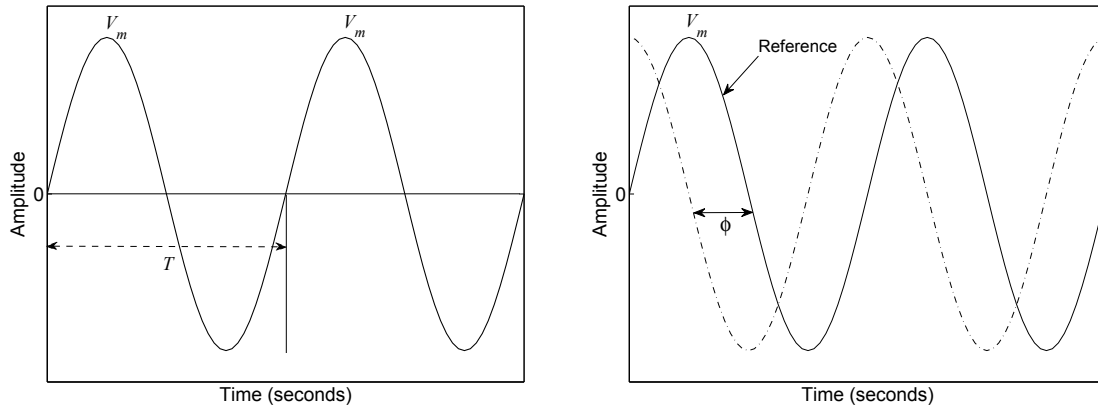

(a) Sinusoidal waveform and related parameters.

(b) Phase shift between two sine waves.

**Figure 4.1:** Parameters of a sine wave (a) Amplitude and time period, (b) Phase

$$v(t) = V_m \sin(\omega t + \phi) \tag{4.1}$$

where

- $V_m$  → amplitude or peak value
- $\omega = 2\pi f = \frac{2\pi}{T}$  → angular frequency in rad/s
- $\phi$  → phase angle in degrees or radians

when  $\phi = 90^\circ$ ,  $\sin(\omega t + 90^\circ) = \cos(\omega t)$ <sup>1</sup>.

<sup>1</sup>use the trigonometric identity  $\sin(\alpha + \beta) = \sin \alpha \cos \beta + \cos \alpha \sin \beta$

# YOUR WORK AT TOMTOM WILL BE TOUCHED BY MILLIONS. AROUND THE WORLD. EVERYDAY.

Join us now on [www.TomTom.jobs](http://www.TomTom.jobs)  
follow us on **LinkedIn**





**#ACHIEVEMORE**
**TOMTOM** 



### 4.2.1 Other Sinusoidal Parameters

#### Mean or Average Value

Given a discrete sequence of signals such as 1, 2, 3, 4, 5 the average value is calculated as follows

$$\text{Average Value} = \frac{1 + 2 + 3 + 4 + 5}{5} = 3$$

For a continuous periodic waveform such as a sinusoid, the mean value can be found by averaging all the instantaneous values during one cycle. This is given by

$$V_{av} = \frac{1}{T} \int_0^T v(t) d(t) \tag{4.2}$$

Clearly, the average value of a complete sine wave is 0 because of equal positive and negative half cycles. This is regardless of the peak amplitude.

**Average value of a fully rectified sine wave** By taking the absolute value of a sine wave, a fully rectified waveform can be generated. In practise, this can be achieved by employing the bridge circuit shown in Figure 4.2(a) with sine wave as the excitation signal. The output waveform across the load,  $R_L$  is depicted in Figure 4.2(b) with a time period of  $T/2$  where  $T$  is the time period of a normal sine wave. Thus

$$V_{av} = \frac{2}{T} \int_0^{T/2} v(t) d(t)$$

$$\boxed{V_{av} = \frac{2V_m}{\pi}} \tag{4.3}$$

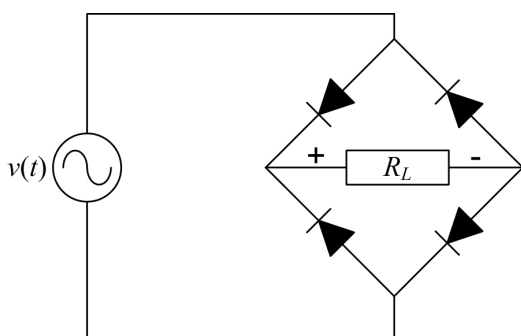

(a) Full wave rectification circuit (commonly known as a bridge rectifier).

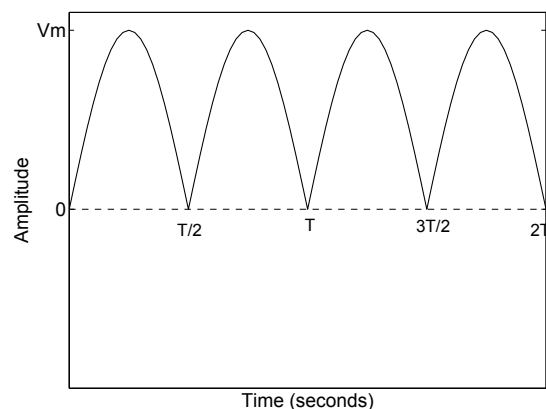

(b) Fully rectified sine waveform.

**Figure 4.2:** A bridge rectifier and the resulting fully rectified sine waveform

A bridge rectifier circuit is common in DC power supplies and is mainly employed to convert an AC input signal to a DC output.

**Average value of a half rectified sine wave** A half wave rectification circuit is depicted in Figure 4.3(a) and the resulting waveform is also shown in Figure 4.3(b). In this case, the negative half cycle of the sine wave is clipped to zero and hence the time period  $T$  of the waveform remains the same. Therefore,

$$V_{av} = \frac{1}{T} \int_0^{T/2} v(t) dt + \frac{1}{T} \int_{T/2}^T 0 \cdot dt$$

$$V_{av} = \frac{V_m}{\pi}$$

(4.4)

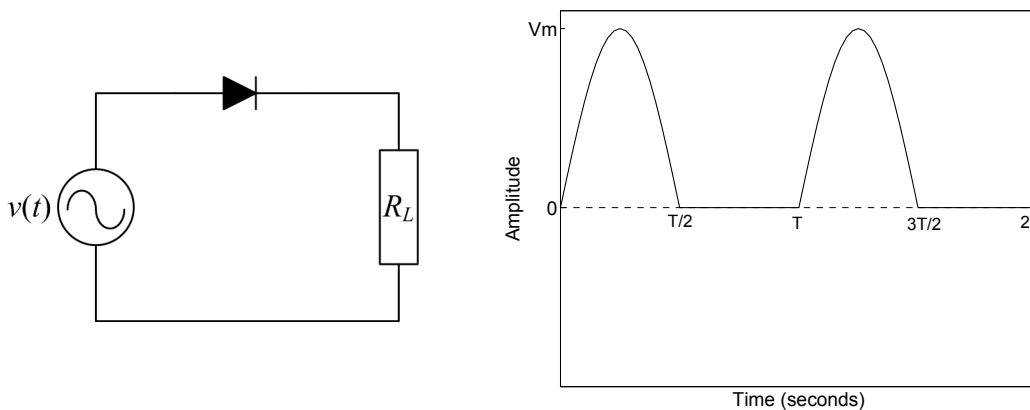

(a) Half wave rectification circuit using a single diode.

(b) Half wave rectified sine waveform.

**Figure 4.3:** A half wave rectification circuit and the resulting output.

A half wave rectifier is also commonly employed in DC power supplies for AC to DC conversion. This requires just one diode as opposed to four in a bridge rectifier. However, the average value is half of the full wave as given by Equation 4.4.

### Effective or RMS Value

The effective or root mean square (RMS) value of a periodic signal is equal to the magnitude of a DC signal which produces the same heating effect as the periodic signal when applied across a load resistance.

Consider a periodic signal,  $v(t)$ , then

$$\begin{aligned} \text{Mean} &= \frac{1}{T} \int_0^T v(t) dt \\ \text{Mean Square} &= \frac{1}{T} \int_0^T v^2(t) dt \\ \text{Root Mean Square} &= \sqrt{\frac{1}{T} \int_0^T v^2(t) dt} \end{aligned} \tag{4.5}$$

The RMS value of a sine wave is found out to be

$$\boxed{V_{rms} = \frac{V_m}{\sqrt{2}}} \quad (4.6)$$

*The mains voltage of 230 V in the UK is its RMS value. A multimeter measures RMS voltages whereas an oscilloscope measures peak amplitudes. Hence the mains voltage when displayed on an oscilloscope will read  $230 \times \sqrt{2} = 325.27$  V*

All the above expressions are independent of the phase angle  $\phi$ .

### 4.3 Voltage, Current Relationships for $R$ , $L$ and $C$

The AC voltage-current relationships for a resistor, inductor and capacitor in an electric circuit are given by

$$R \rightarrow v_R(t) = R i(t) \quad (4.7)$$

$$L \rightarrow v_L(t) = L \frac{di(t)}{dt} \quad (4.8)$$

$$C \rightarrow v_C(t) = \frac{1}{C} \int i(t) dt \quad (4.9)$$

if  $i(t) = I_m \sin(\omega t)$ , then

$$v_R(t) = R I_m \sin(\omega t) \quad (4.10)$$

$$v_L(t) = L \frac{d}{dt} I_m \sin(\omega t) = \omega L I_m \cos(\omega t) = \omega L I_m \sin(\omega t + 90^\circ) \quad (4.11)$$

$$v_C(t) = \frac{1}{C} \int I_m \sin(\omega t) dt = \frac{-I_m}{\omega C} \cos(\omega t) = \frac{I_m}{\omega C} \sin(\omega t - 90^\circ) \quad (4.12)$$

It is clear that with AC excitation, all voltages and currents retain the basic sine wave shape as depicted in Figure 4.4(a).

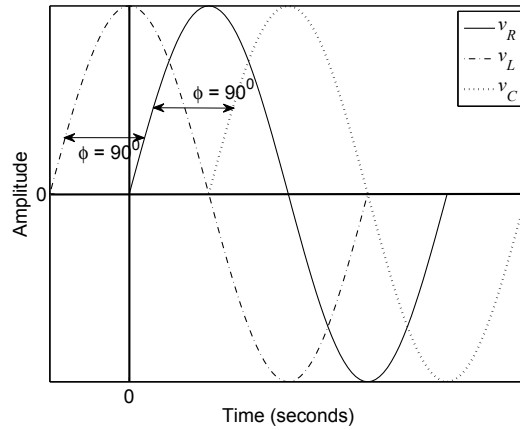

(a) Voltage waveforms across  $R$ ,  $L$  and  $C$  showing the phase difference.

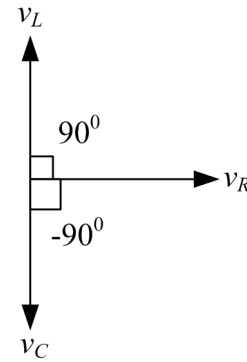

(b) Vector diagram showing  $V - I$  phase lag/lead concept in  $RLC$ .

**Figure 4.4:** Phase difference between voltages across  $R$ ,  $L$  and  $C$ .

However, a phase difference of  $90^\circ$  (lead) and  $-90^\circ$  (lag) with respect to the input current is observed in the inductor and capacitor voltages respectively. This is demonstrated in the vector diagram of Figure 4.4(b). A simple way to remember this concept is to consider a CIVIL relationship where  $C$ ,  $L$ ,  $V$  and  $I$  represents capacitor, inductor, voltage and current respectively.

This reads as

In a Capacitor ( $C$ ), current,  $I$  leads voltage,  $V$  whereas  $V$  leads  $I$  in an inductor ( $L$ ).

### 4.4 Impedance

From Equations 4.10, 4.11 and 4.12, the magnitudes of the ratio of voltage to current across the three circuit elements can be written as

$$\left| \frac{V_R}{I_m} \right| = R \tag{4.13}$$

$$\left| \frac{V_L}{I_m} \right| = \omega L \tag{4.14}$$

$$\left| \frac{V_C}{I_m} \right| = \frac{1}{\omega C} \tag{4.15}$$

where  $\omega L$  and  $\frac{1}{\omega C}$  have the dimensions of resistance ( $\Omega$ ) and are termed as inductive reactance and capacitive reactance respectively i.e.

$$X_L = \omega L \rightarrow \text{inductive reactance}$$

$$X_C = \frac{1}{\omega C} \rightarrow \text{capacitive reactance}$$

The impedance,  $Z$  can now be defined by the following relationship

$$\begin{aligned}\text{Impedance} &= \text{Resistance} \pm j \text{Reactance} \\ \text{or } Z &= R + jX \quad \text{where } j \text{ represents a } 90^\circ \text{ phase shift}\end{aligned}$$

$X$  is positive for inductance and negative for capacitance. The magnitude and phase of the impedance can be calculated as follows

$$|Z| = \sqrt{R^2 + X^2} \quad (4.16)$$

$$\phi = \arctan \pm \frac{X}{R} \quad (4.17)$$

**Admittance** The reciprocal of impedance is called admittance ( $Y$ ) and is measured in  $\text{S}$ . Mathematically

$$Y = \frac{1}{Z} = \frac{I}{V}$$

Also  $Y = G \pm jB$ , where  $G$  and  $B$  represents conductance and susceptance respectively. For a purely resistive or purely inductive/capacitive circuit

$$G = \frac{1}{R} \text{ and } B = \frac{1}{X}$$

For a combination of resistance and reactance

$$Y = \frac{1}{Z} = \frac{1}{R + jX}$$

multiply and divide by the complex conjugate

$$Y = \frac{R - jX}{R^2 + X^2}$$

$$Y = \frac{R}{R^2 + X^2} - j \frac{X}{R^2 + X^2}$$

$$\therefore G = \frac{R}{R^2 + X^2} \quad \& \quad B = \frac{X}{R^2 + X^2}$$

## 4.5 Phasors

Addition of two *out-of-phase* sinusoidal signals is rather complicated in the time domain. An example could be the sum of voltages across a series connection of a resistor and an inductor.

Phasors simplify this analysis by considering only the amplitude and phase components of the sine wave. Moreover, they can be solved using complex algebra or treated vectorially using a vector diagram.

Consider a vector quantity  $\mathbf{A}$  in the complex plane as shown in Figure 4.5(a). Then

$$\mathbf{A} = x + j y \tag{4.18}$$

where  $x = A \cos \theta$  and  $y = A \sin \theta$ , therefore

$$\begin{aligned} \mathbf{A} &= A \cos \theta + j A \sin \theta \\ &= A (\cos \theta + j \sin \theta) \\ \therefore e^{j\theta} &= \cos \theta + j \sin \theta \text{ (Euler's formula)} \end{aligned} \tag{4.19}$$

$$\therefore \mathbf{A} = A e^{j\theta} \tag{4.20}$$

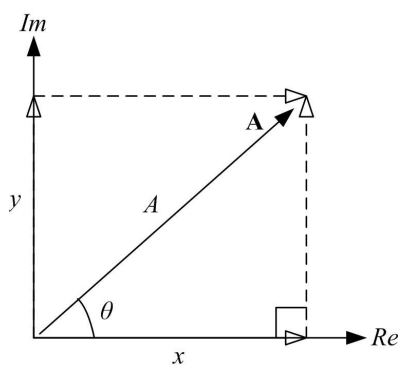

(a) Phasor as a vector

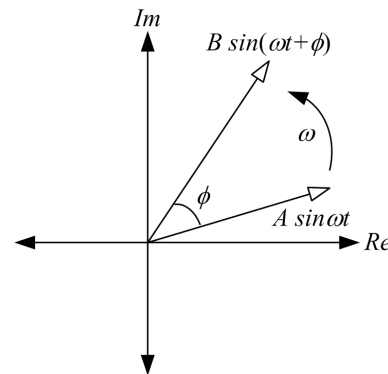

(b) Relative motion of two phasors

**Figure 4.5:** Vector representation of a phasor.

# Brain power



Plug into The Power of Knowledge Engineering.  
Visit us at [www.skf.com/knowledge](http://www.skf.com/knowledge)

By 2020, wind could provide one-tenth of our planet's electricity needs. Already today, SKF's innovative know-how is crucial to running a large proportion of the world's wind turbines.

Up to 25 % of the generating costs relate to maintenance. These can be reduced dramatically thanks to our systems for on-line condition monitoring and automatic lubrication. We help make it more economical to create cleaner, cheaper energy out of thin air.

By sharing our experience, expertise, and creativity, industries can boost performance beyond expectations. Therefore we need the best employees who can meet this challenge!

The Power of Knowledge Engineering





Equation 4.20 is the phasor notation of the vector  $\mathbf{A}$  where  $A$  is the length of the vector or amplitude of the signal and  $\theta$  is the angle which  $\mathbf{A}$  makes with a reference phasor.

**Rotating Vector Concept** Let  $\theta = \omega t$ , therefore  $\mathbf{A} = Ae^{j\omega t}$  where  $\omega$  is the angular velocity and  $t$  is the time. Then  $\mathbf{A}$  can be regarded as a vector rotating with an angular velocity  $\omega$ . Now if two phasors are rotating with the same velocity as illustrated in Figure 4.5(b), then their relative positions are unchanged with respect to time and therefore can be added.

*Two or more sinusoidal signals can be added mathematically using phasors if they all have the same angular velocities.*

Polar form is also commonly used to represent a phasor and is given by the magnitude (modulus) and phase (argument) of the signal i.e.,

$$\mathbf{A} = A\angle\theta$$

It may be convenient to transform the polar form into cartesian form (Equation 4.18) and vice versa when adding two sinusoidal signals.

### Example

Express the following as phasors and write the corresponding polar and cartesian forms.

1.  $5 \sin(\omega t + 45^\circ)$
2.  $2 \cos(\omega t)$
3.  $10 \sin(\omega t)$
4.  $3 \cos(\omega t + 30^\circ)$

### Solution

1.  $5e^{j45^\circ}$  or  $5e^{j\pi/4}$  (phasor notation)
  - (a)  $5\angle 45^\circ$  (polar form)
  - (b)  $5 \cos 45^\circ + j5 \sin 45^\circ = 3.54 + j3.54$  (cartesian form)
2.  $2 \sin(\omega t + 90^\circ) = 2e^{j90^\circ}$  (phasor notation)
  - (a)  $2\angle 90^\circ$  (polar form)
  - (b)  $2 \cos 90^\circ + j2 \sin 90^\circ = 0 + j2$  (cartesian form)
3.  $10e^{j0^\circ}$  (phasor notation)
  - (a)  $10\angle 0^\circ$  (polar form)
  - (b)  $10 \cos 0^\circ + j10 \sin 0^\circ = 10 + j0$  (cartesian form)
4.  $3 \sin(\omega t + 30^\circ + 90^\circ) = 3 \sin(\omega t + 120^\circ) = 3e^{j120^\circ}$  (phasor notation)

(a)  $3\angle 120^\circ$  (polar form)

(b)  $3 \cos 120^\circ + j3 \sin 120^\circ = -1.5 + j2.6$  (cartesian form)

In the above examples and all other instances in this book,  $\sin \omega t$  is used as a reference for phasor conversion. This means that a cosine signal is converted to a sine wave before writing the phasor notation. It is also valid to use  $\cos \omega t$  as reference, however, consistency is required in a given problem.

**Example**

Express the following as sinusoids.

1.  $2e^{j\pi/2}$

2.  $5e^{j\pi/4}$

3.  $5 + 6j$

4.  $3e^{j120^\circ}$

**Solution**

1.  $2 \sin(\omega t + \pi/2) = 2 \cos \omega t$

2.  $5 \sin(\omega t + \pi/4)$

3.  $\sqrt{5^2 + 6^2} = 7.81$ ,  $\tan^{-1} \frac{6}{5} = 50.2^\circ \Rightarrow 7.81\angle 50.2^\circ = 7.81 \sin(\omega t + 50.2^\circ)$

4.  $3 \sin(\omega t + 120^\circ)$  or  $3 \sin(\omega t + 30^\circ + 90^\circ) = 3 \cos(\omega t + 30^\circ)$

**Example**

Add the following two sinusoidal signals using (a) complex algebra (b) vector diagram.

$$v_1(t) = 2 \sin(5t + 30^\circ)$$

$$v_2(t) = \sin(5t + 60^\circ)$$

**Solution (a)** Since  $\omega = 5$  rad/s for both sinusoids, hence phasors can be employed to add these signals.

The polar form representation for  $v_1$  and  $v_2$  is

$$\mathbf{V}_1 = 2\angle 30^\circ, \quad \mathbf{V}_2 = 1\angle 60^\circ$$

The sum of the phasors is given by

$$\mathbf{V} = \mathbf{V}_1 + \mathbf{V}_2$$

$$\begin{aligned} \mathbf{V} &= 2\angle 30^\circ + 1\angle 60^\circ \\ &\text{converting polar to cartesian coordinates} \\ &= 2 \cos 30^\circ + j2 \sin 30^\circ + \cos 60^\circ + j \sin 60^\circ \\ &= 1.732 + j + 0.5 + j0.866 \\ &= 2.232 + j1.866 \\ &\text{converting back to polar form} \\ \mathbf{V} &= 2.91\angle 39.9^\circ \\ \therefore v(t) &= 2.91 \sin(5t + 39.9^\circ) \end{aligned}$$

**Solution (b)** See vector diagram in Figure 4.6 for the solution.

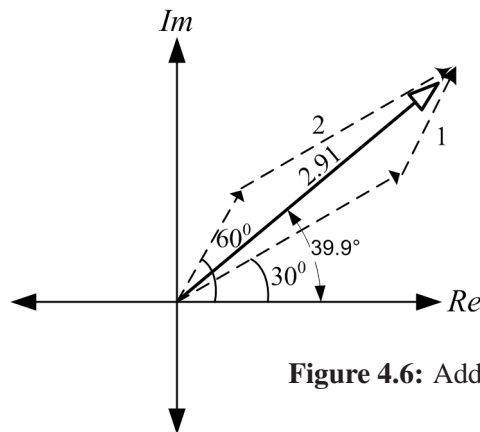

**Figure 4.6:** Addition of phasors using a vector diagram.



## 4.6 Phasor Analysis of AC Circuits

Fortunately, the techniques employed for DC circuit analysis can be reused for AC circuits by following the procedure outlined below:

1. Replace sinusoidal voltages and currents,  $v$  and  $i$  by their respective phasors.
2. Replace the linear circuit elements  $R$ ,  $L$  and  $C$  by their respective impedances  $R$ ,  $j\omega L$  and  $-j/(\omega C)$ .
3. Use DC circuit laws redefined for AC circuits below to evaluate the required voltage and current phasors. Complex algebra will have to be employed to simplify the equations.

a. Ohms law  $V = ZI$

b. KVL  $\sum V = 0$  (mesh voltages)

c. KCL  $\sum I = 0$  (nodal currents)

d. Impedances in series:  $Z = Z_1 + Z_2 + \dots$

e. Impedances in parallel:  $\frac{1}{Z} = \frac{1}{Z_1} + \frac{1}{Z_2} + \dots$  or  $Y = Y_1 + Y_2 + \dots$

f. VDR (impedances in series)  $V_i = V \cdot \frac{Z_i}{\sum Z}$

g. CDR (impedances in parallel)  $I_i = I \cdot \frac{Y_i}{\sum Y}$

4. Convert the voltage and current phasors back to sinusoidal form using the techniques learned in the previous section.

### Example

Use phasor analysis to determine the voltage across the terminals  $a$  and  $b$  in the circuit diagram of Figure 4.7.

In phasor form, the supply voltage can be written as

$$\mathbf{V} = 10\angle 0^\circ \text{ where } \omega = 2\text{rad/s}$$

The  $1\ \Omega$  resistance and  $1\ \text{H}$  inductance can be combined into a single impedance  $Z_1$ . Similarly the  $2\ \Omega$  resistance and  $1\ \text{F}$  capacitor can be added to form  $Z_2$  as shown in Figure 4.7.

$$\therefore Z_1 = R + j\omega L = 1 + j2 \times 1 = 1 + j2\ \Omega$$

Also

$$Z_2 = R + 1/(j\omega C) = 2 + 1/(j2 \times 1) = 2 - j0.5\ \Omega$$

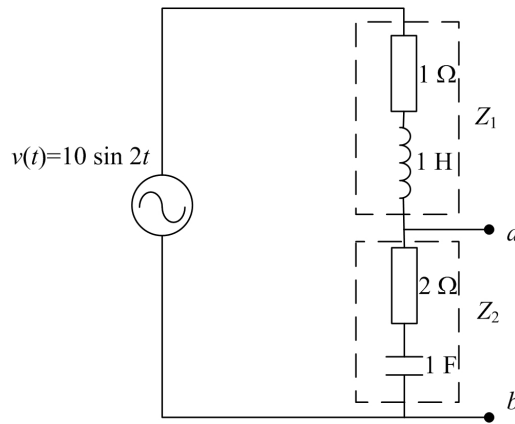

Figure 4.7

Steps 1 and 2 of AC circuit analysis have now been completed whereas step 3 entails the use of one of the circuit laws. Since both  $Z_1$  and  $Z_2$  are in series with the voltage source, therefore VDR can be applied to determine the voltage across  $Z_2$  which is also the voltage across the terminals  $a$  and  $b$ .

$$\begin{aligned}
 \mathbf{V}_{ab} &= V \frac{Z_2}{Z_1 + Z_2} \\
 &= 10 \angle 0^\circ \frac{2 - j0.5}{1 + j2 + 2 - j0.5} \\
 &= 10 \angle 0^\circ \cdot \frac{2.06 \angle -14.04^\circ}{3.35 \angle 26.56^\circ} \\
 &= \frac{10 \times 2.06}{3.35} \angle (0^\circ - 14.04^\circ - 26.56^\circ) \\
 \mathbf{V}_{ab} &= 6.15 \angle -40.6^\circ \\
 \therefore v_{ab}(t) &= 6.15 \sin(2t - 40.6^\circ) \text{ V}
 \end{aligned}$$

**Example**

For the circuit diagram shown in Figure 4.8, determine the voltage  $V$  across the  $5 \Omega$  impedance and specify it in time domain when  $\omega = 1000 \text{ rad/s}$ .

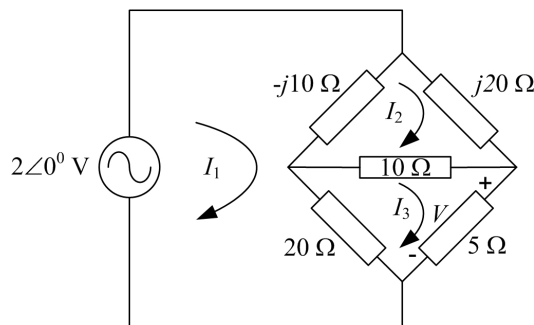

Figure 4.8

The circuit for this example is an AC bridge circuit which is similar to the bridge rectifier circuit in Figure 4.2(a). This can be solved using mesh analysis with mesh currents  $I_1$ ,  $I_2$  and  $I_3$  as shown.

*Mesh 1*

$$\begin{aligned}(I_1 - I_2)(-j10) + (I_1 - I_3)(20) &= 2 \\ (20 - j10)I_1 + j10I_2 - 20I_3 &= 2\end{aligned}\quad (4.21)$$

*Mesh 2*

$$\begin{aligned}(I_2 - I_1)(-j10) + j20I_2 + (I_2 - I_3)(10) &= 0 \\ j10I_1 + (10 + j10)I_2 - 10I_3 &= 0\end{aligned}\quad (4.22)$$

*Mesh 3*

$$\begin{aligned}(I_3 - I_1)(20) + (I_3 - I_2)(10) + I_3(5) &= 0 \\ -20I_1 - 10I_2 + 35I_3 &= 0\end{aligned}\quad (4.23)$$

Equations 4.21-4.23 can be solved simultaneously to determine the unknown mesh currents using Cramer's rule as outlined in Appendix A. In this case, since the voltage across the  $5\ \Omega$  resistance is required, therefore only the current  $I_3$  is evaluated using the following relationship.

$$I_3 = \frac{\Delta_3}{\Delta}$$

## LIGS University

### based in Hawaii, USA

is currently enrolling in the  
Interactive Online **BBA, MBA, MSc,**  
**DBA and PhD** programs:

- ▶ enroll **by October 31st, 2014** and
- ▶ **save up to 11%** on the tuition!
- ▶ pay in 10 installments / 2 years
- ▶ Interactive **Online education**
- ▶ visit [www.ligsuniversity.com](http://www.ligsuniversity.com) to find out more!

Note: LIGS University is not accredited by any nationally recognized accrediting agency listed by the US Secretary of Education. More info [here](#).





where

$$\Delta_3 = \begin{vmatrix} 20 - j10 & j10 & 2 \\ j10 & 10 + j10 & 0 \\ -20 & -10 & 0 \end{vmatrix} \quad \text{and} \quad \Delta = \begin{vmatrix} 20 - j10 & j10 & -20 \\ j10 & 10 + j10 & -10 \\ -20 & -10 & 35 \end{vmatrix}$$

$$I_3 = 0.05 - j0.0024 \text{ (A)} = 0.05 \angle -2.8^\circ \text{ A}$$

$$\therefore \mathbf{V} = 5 \times I_3 = 5 \times 0.05 \angle -2.8^\circ = 0.25 \angle -2.8^\circ \text{ V}$$

In the time domain

$$v(t) = 0.25 \sin(1000t - 2.8^\circ) \text{ V}$$

The mesh and nodal equations for AC circuits can also be directly written in matrix form by inspection using the same method as outlined in Section 3.11 for DC circuits. However, the  $R$  and  $G$  parameters are replaced by  $Z$  and  $Y$  respectively and complex algebra is employed for all complex numbers computations.

## 4.7 Power in AC Circuits

From DC circuit analysis in Chapter 3, power is given by the following relationship

$$P = VI \text{ Watts}$$

Therefore the instantaneous power is given by  $p(t) = v(t) \cdot i(t)$ . Let  $i(t) = I_m \sin(\omega t + \beta)$  be the current flowing through an impedance,  $Z$ , then the voltage across the impedance will be  $v(t) = V_m \sin(\omega t + \alpha)$ . Therefore

$$p(t) = V_m I_m \sin(\omega t + \alpha) \sin(\omega t + \beta)$$

Using the trigonometric identity

$$\sin A \sin B = \frac{1}{2} [\cos(A - B) - \cos(A + B)]$$

$$p(t) = -\frac{1}{2} V_m I_m \cos(2\omega t + \alpha + \beta) + \frac{1}{2} V_m I_m \cos(\alpha - \beta) \quad (4.24)$$

The first term is a time-varying sinusoidal waveform with twice the frequency of  $v(t)$  or  $i(t)$  and an average value of zero. On the other hand, the second term is a constant quantity and is called the DC level or average value of the power signal,  $p(t)$  or average power delivered to the load i.e.,

$$\begin{aligned} P_{av} &= \frac{1}{2} V_m I_m \cos(\alpha - \beta) \\ P_{av} &= \frac{1}{2} V_m I_m \cos(\phi) \end{aligned} \quad (4.25)$$

where  $\phi = \alpha - \beta$  is the phase angle between  $v(t)$  and  $i(t)$ .

The waveform  $p(t)$  is plotted in Figure 4.9 for an arbitrary value of  $\phi$  where the negative shaded portion of the waveform is the power returned (not absorbed by the load) to the source.

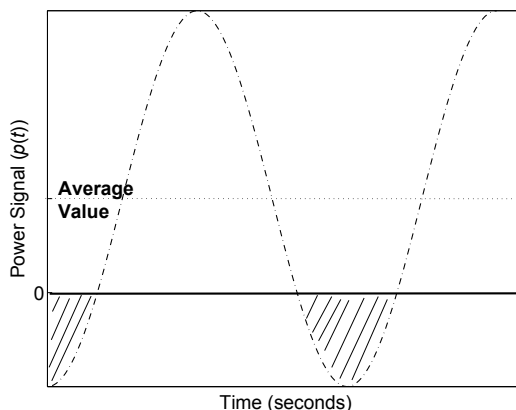
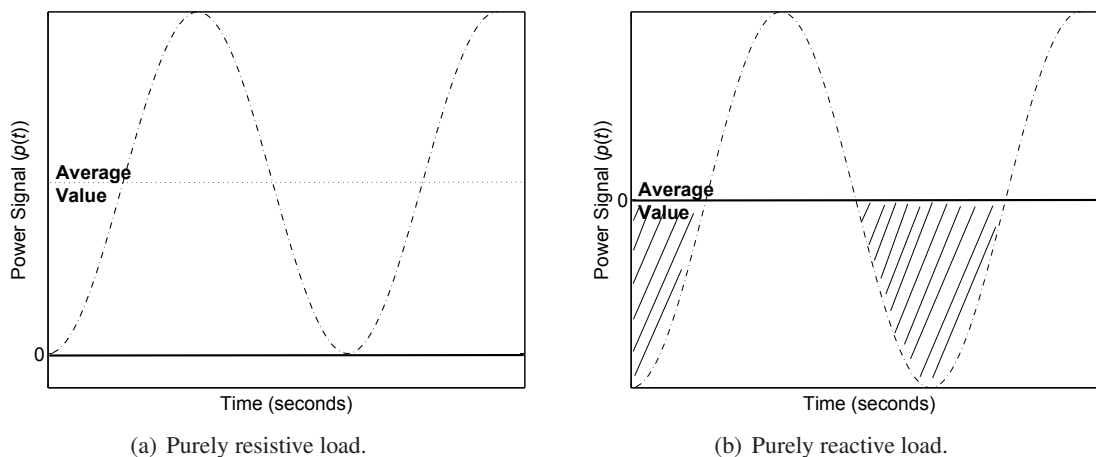

**Figure 4.9:** Power supplied to a generic load impedance.

For a purely resistive load ( $\phi = 0^\circ$ ), Equation 4.25 becomes

$$P_{av} = \frac{1}{2} V_m I_m$$

and the resulting power signal,  $p(t)$  is depicted in Figure 4.10(a). In this case, there is no negative portion of the waveform and hence all the power is dissipated in the load.



**Figure 4.10:** Power supplied to purely resistive and reactive loads.

For a purely reactive load, i.e.,  $Z = \pm jX$ ,  $\phi = 90^\circ$  and  $P_{av} = 0$ . The power signal waveform is drawn in Figure 4.10(b) showing that the power oscillates between the source and electric/magnetic field of the load. Thus the power dissipated in the load is zero for a purely reactive load.

In terms of RMS voltage and current, the average power is given by

$$P_{rms} = V_{rms} I_{rms} \cos \phi \quad (4.26)$$

## 4.8 Power Factor

The term  $\cos \phi$  in Equation 4.25 is called the *power factor* and is an important parameter in determining the amount of actual power dissipated in the load. In practise, power factor is used to specify the characteristics of a load.

**For a purely resistive load**  $\phi = 0^\circ$ , hence *Unity* Power Factor

**For a capacitive type load**  $I$  leads  $V$ , hence *Leading* power factor

**For an inductive type load**  $I$  lags  $V$ , hence *Lagging* power factor

From Equation 4.26, the current can be specified as

$$I_{rms} = \frac{P_{rms}}{V_{rms} \cos \phi}$$

Clearly, for a fixed amount of demanded power,  $P$ , at a constant load voltage,  $V$ , a higher power factor draws less amount of current and hence low  $I^2R$  losses in the transmission lines. A purely reactive load where  $\phi \rightarrow 90^\circ$  and  $\cos \phi \rightarrow 0$  will draw an excessively large amount of current and a power factor correction is required as discussed in the next section.

# TURN TO THE EXPERTS FOR SUBSCRIPTION CONSULTANCY

Subscribe is one of the leading companies in Europe when it comes to innovation and business development within subscription businesses.

We innovate new subscription business models or improve existing ones. We do business reviews of existing subscription businesses and we develop acquisition and retention strategies.

Learn more at [linkedin.com/company/subscribe](https://www.linkedin.com/company/subscribe) or contact Managing Director Morten Suhr Hansen at [mha@subscribe.dk](mailto:mha@subscribe.dk)

**SUBSCRIBE** - to the future



**Real and Apparent Power** It is important to highlight that in AC circuits, the product of voltage and current yields the apparent power which is measured in volt-amperes<sup>2</sup> or VA. The real AC power is given by Equation 4.26 which is measured in Watts.

**Example**

An AC generator is rated at 900 kVA (450 V /2000 A). This is the apparent power and represents the highest current and voltage magnitudes the machine can output without temperature exceeding the recommended value. The load voltage, however, could be 230 V with a supplied current depending on the load impedance. The phase angle between the current and voltage determines the power factor and the real power can be calculated using Equation 4.26.

**4.8.1 Power Factor Correction**

As mentioned above, to minimise  $I^2R$  losses in AC networks, it may be necessary to manipulate the power factor. This can be achieved by connecting a purely reactive impedance,  $Z'$  in parallel with the load impedance as depicted in Figure 4.11.

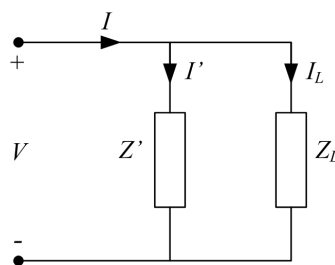

**Figure 4.11:** Power factor correction by introducing a pure reactance in parallel with the load impedance.

By doing so, the phase angle between the line voltage and line current can be adjusted whereas the power consumption remains the same since a pure reactance does not dissipate any power (see Figure 4.10(b)). A carefully chosen reactance will decrease  $\phi$  and thus increases the power factor which in turn reduces the line current.

**Example**

Given that the RMS line voltage and line current are  $\mathbf{V} = 100\angle 0^\circ$  V and  $\mathbf{I} = 50\angle -36.9^\circ$  A respectively, determine the impedance which will result in a unity power factor.

Taking voltage as the reference phasor, the phase angle between the line voltage and line current is  $-36.9^\circ$

$$\therefore \text{Power factor} = \cos \phi = \cos(-36.9^\circ) = 0.8$$

$$\mathbf{I} = \mathbf{I}_L = 50\angle -36.9^\circ = 40 - j30 \text{ A}$$

---

<sup>2</sup>In DC circuits, the product of voltage and current is the real power measured in Watts.

$$\therefore \text{real power } P = |V||I| \cos \phi = 100 \times 50 \times 0.8 = 4 \text{ kW}$$

To improve the power factor, an impedance is inserted in parallel with the load as in Figure 4.11 resulting in the following nodal equation

$$I = I_L + I'$$

It is clear that for unity power factor, the imaginary component of the line current must be zero. This is accomplished by assigning a current of  $j30$  A through the pure reactance resulting in the following line current

$$I = (40 - j30) + (j30) = 40 \text{ A}$$

Thus  $I' = j30$  A and the magnitude of the impedance required can be calculated as follows

$$Z' = \frac{V}{I'} = \frac{100}{j30} = -j3.33 \Omega$$

The power consumed by the load remains the same i.e.

$$P = |V||I| \cos \phi = 100 \times 40 \times 1 = 4 \text{ kW}$$

Thus to achieve unity power factor, a pure reactance of  $-j3.33 \Omega$  is connected in parallel with the load.

The vector diagram of the above example is shown in Figure 4.12.

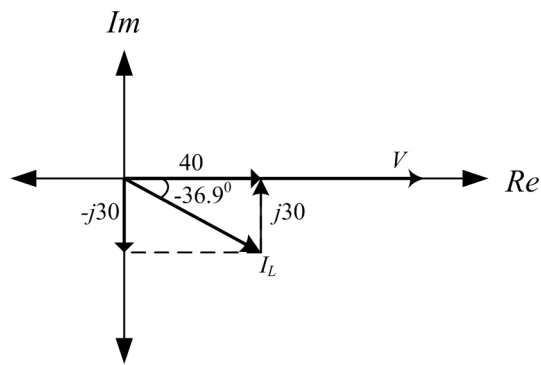

**Figure 4.12:** Vector diagram to illustrate power factor correction.

## Chapter 5

# Frequency Response

### 5.1 Introduction

The AC circuits concepts presented so far assumes sinusoidal excitation at a fixed frequency. It was mentioned that two or more signals can be combined using phasors provided they all have the same frequency. In this chapter, the response of a linear AC circuit is examined when excited with an AC signal of constant amplitude but varying frequency hence the term frequency response. These signals are common in everyday application areas such in a radio, television and telephone and can be studied using frequency response analysis. In addition, filter circuits are introduced and their output response is observed. Techniques to draw approximate frequency response plots by inspection is described in the end.

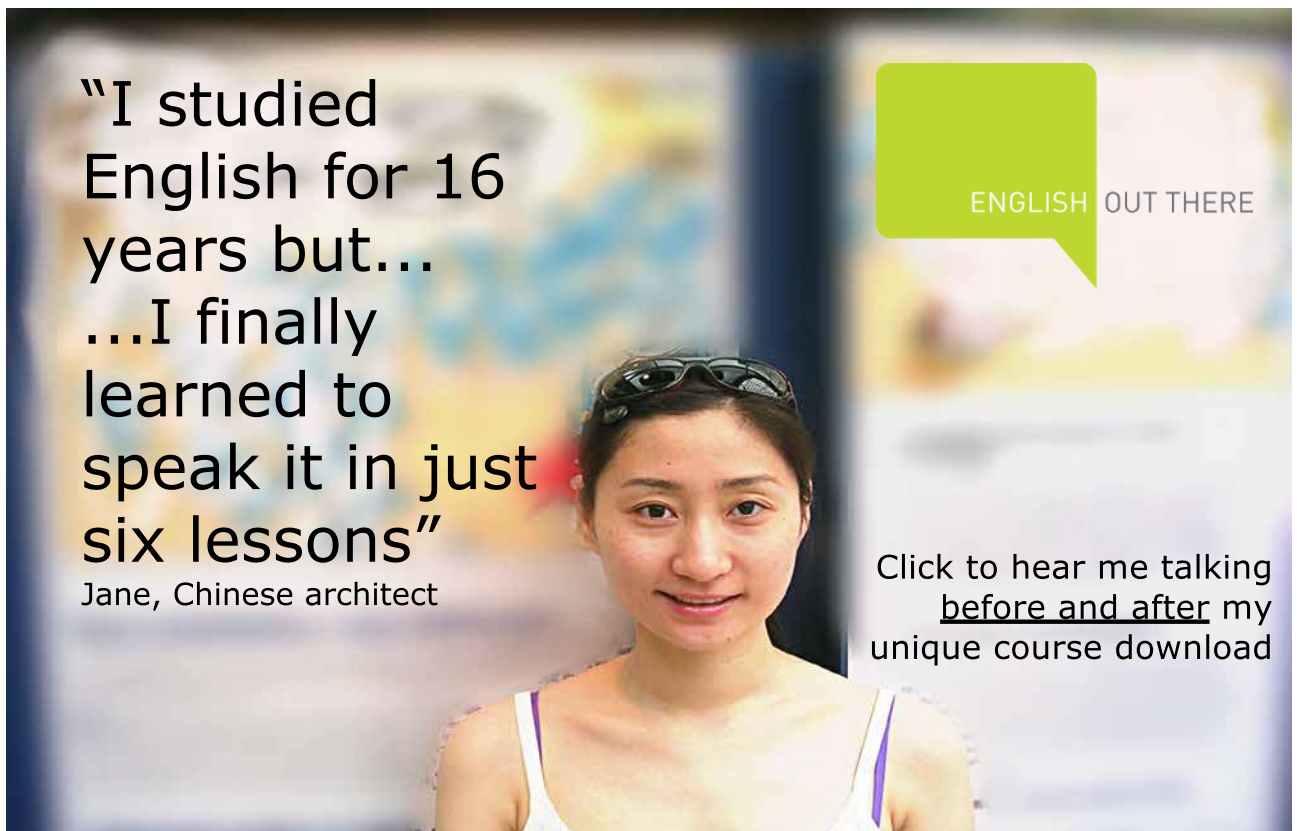

"I studied English for 16 years but...  
...I finally learned to speak it in just six lessons"  
Jane, Chinese architect

ENGLISH OUT THERE

Click to hear me talking before and after my unique course download



## 5.2 Frequency Response

To understand the concept of frequency response, consider a linear circuit with input and output voltage signals represented by  $V_i$  and  $V_o$  respectively as shown in Figure 5.1.

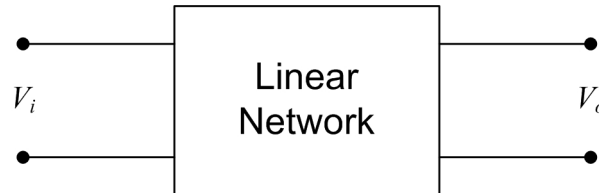

**Figure 5.1:** A two port linear network showing the input and output voltage signals.

Now if the input amplitude  $V_i$  is kept constant whilst its frequency  $\omega$  (rad/s) is varied, then it is observed that the amplitude and phase of the output signal  $V_o$  will also change. However, the input and output frequencies remain unaltered. This means that  $V_o$  and  $\phi$  become functions of the frequency  $\omega$  represented by  $V_o(\omega)$  and  $\phi(\omega)$  with  $V_i$  being the reference signal.

The ratio of the output to input voltage signal is denoted by  $H(j\omega)$  which is a complex function and can be written mathematically as

$$H(j\omega) = \frac{V_o}{V_i} \quad (5.1)$$

In polar form

$$\mathbf{H}(\mathbf{j}\omega) = \frac{|V_o(\omega)|\angle\theta^0(\omega)}{|V_i|\angle 0^0} \quad (5.2)$$

$$\text{or } \mathbf{H}(\mathbf{j}\omega) = A\angle\phi \quad (5.3)$$

where the voltage gain  $A = |H(j\omega)|$  and  $\phi = \arg H(j\omega)$  are both functions of frequency,  $\omega$ .

**Amplitude Response** The variations recorded in the amplitude gain,  $A$  with respect to  $\omega$  is called the amplitude response of the network.

**Phase Response** The variations observed in the phase,  $\phi$  of the network with respect to  $\omega$  is known as the phase response.

The amplitude and phase outputs together define the frequency response of a network.

In the next section, filters are introduced and their response to an input signal with varying frequency is observed. This will help further to clarify the concepts of frequency response analysis.

### 5.3 Filters

Filters form a vital part in electrical networks especially where a particular frequency range is of prime concern. For instance, a radio station is broadcasting a transmission at a frequency of 100 MHz. This means that it is required to design a receiving filter which allows only 100 MHz frequency to pass through whilst other frequencies are filtered out. An ideal filter will attenuate all signals with frequencies less than and greater than 100 MHz thus providing the best channel sound quality without any distortion.

The following sections outline the most commonly used filters found in electric circuits and their respective frequency responses. This includes low pass, high pass and band pass filters.

#### 5.3.1 Low Pass Filter

A low pass filter *allows* low frequencies to pass through the circuit whereas high frequencies are severely attenuated or blocked. Figure 5.2(a) depicts a low pass filter constructed using a simple  $RC$  network. The output voltage,  $V_o$  is taken across the capacitor.

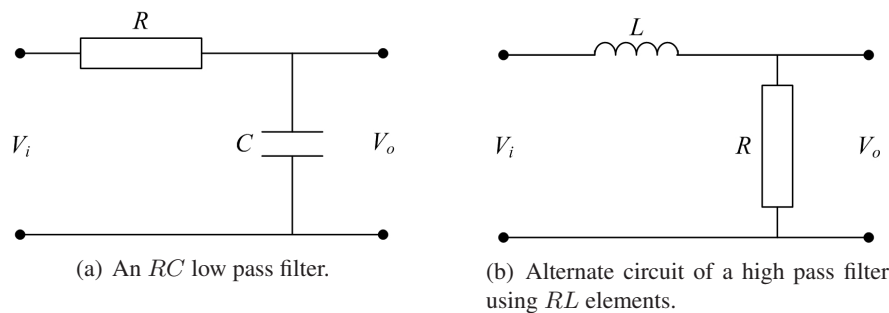

**Figure 5.2:** Two different circuits used to construct a low pass filter.

Note that it is also possible to construct a low pass filter using an  $RL$  combination as shown in Figure 5.2(b). Herein, the analysis is restricted to  $RC$  circuit only whereas the  $RL$  circuit can be observed in a similar manner.

The reactance of the capacitor is  $\frac{1}{j\omega C}$  which will be used in the mathematical analysis of the low pass filter. To determine  $V_o$ , VDR (Chapter 3) can be applied since  $R$  and  $C$  are in series hence share the same current. Therefore

$$V_o = V_i \frac{\frac{1}{j\omega C}}{R + \frac{1}{j\omega C}}$$

$$V_o = V_i \frac{1}{1 + j\omega RC}$$

Let  $T = RC$  be the time constant, then

$$H(j\omega) = \frac{V_o}{V_i} = \frac{1}{1 + j\omega T} \tag{5.4}$$

The output response of Equation 5.4 to a change in input signal frequency is now investigated.

At low frequencies,  $\omega \approx 0$ ,  $\therefore V_o \approx V_i$ , i.e. most of  $V_i$  appears at the output across the capacitor. When  $\omega \rightarrow \infty$ ,  $V_o \rightarrow 0$ , hence output voltage amplitude is severely attenuated i.e. very little of  $V_i$  appear at  $V_o$  at high frequencies. Therefore this circuit acts as a low pass filter. The frequency response can also be visually inspected by plotting the amplitude and phase responses versus frequency. From Equation 5.4, the amplitude response equation of the low pass filter can be derived as

$$A = |H(j\omega)| = \frac{1}{\sqrt{1 + (\omega T)^2}}$$

and the phase is given by

$$\phi = \arg(H(j\omega)) = \tan^{-1}(-\omega T)$$

For  $\omega \approx 0$ ,  $A \approx 1$  and  $\phi \approx 0$

For  $\omega \rightarrow \infty$ ,  $A \rightarrow 0$  and  $\phi \rightarrow -\pi/2$

For  $\omega = \frac{1}{T}$ ,  $A = \frac{1}{\sqrt{2}} = 0.7071$  and  $\phi = -\pi/4 = -45^\circ$

**wethrive.net**

**How to retain your top staff**  
**FIND OUT NOW FOR FREE**

**DO YOU WANT TO KNOW:**

- What your staff really want?
- The top issues troubling them?
- How to make staff assessments work for you & them, painlessly?

**Get your free trial**  
 Because happy staff get more done



The response plots are shown in Figure 5.3.

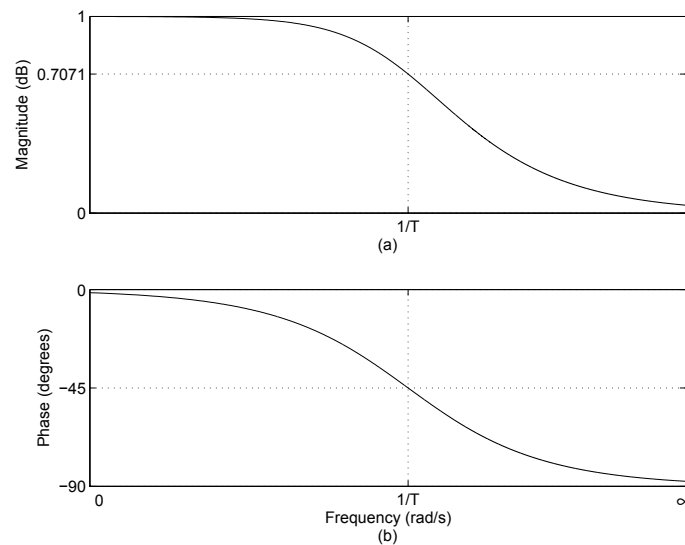

**Figure 5.3:** Frequency response of a low pass filter where (a) Amplitude response (b) Phase response

**Bandwidth** The frequency  $\omega = 1/T$  is the cutoff frequency or bandwidth of the low pass filter. It is defined as the frequency range for which the amplitude  $A \geq \frac{1}{\sqrt{2}}$ . Mathematically, the bandwidth of an  $RC$  low pass filter is given by

$$\text{Bandwidth} = \frac{1}{T} = \frac{1}{RC}$$

Clearly the bandwidth is user and problem dependent and can be adjusted simply by tuning the  $R$  and  $C$  parameters.

It is more common to express the gain,  $A$  of a circuit in Decibels (dB) units given by

$$A_{dB} = 20 \log_{10} A$$

which was originally developed as the logarithmic unit of power ratio i.e.

$$\text{dB Power Gain} = 10 \log_{10} \frac{P_o}{P_i}$$

The amplitude plot in Figure 5.3 is redrawn in Figure 5.4 with gain converted to dB versus logarithm of frequency. The phase response remains unaltered.

Some vital observations can be made on comparing Figures 5.3 and 5.4.

- Zero dB corresponds to a unity gain i.e.  $A = 1$
- Negative dB corresponds to attenuation i.e.  $A < 1$
- Positive dB corresponds to amplification i.e.  $A > 1$

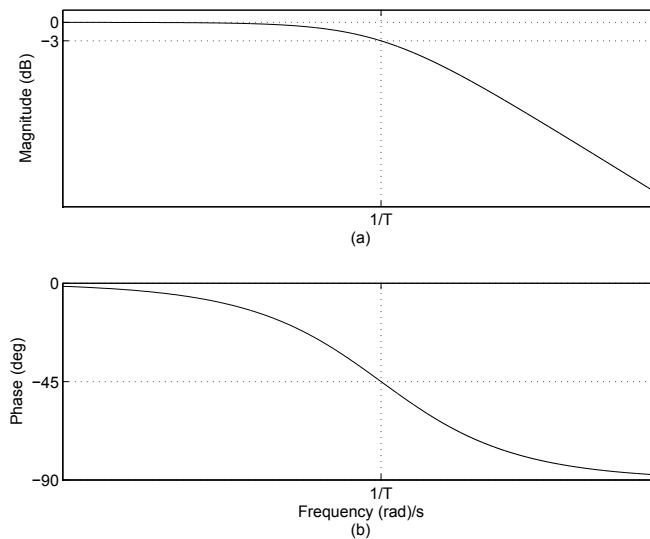

**Figure 5.4:** Frequency response of a low pass filter where (a) Amplitude response in dB (b) Phase response

- The bandwidth of a low pass filter is the frequency range for which the gain,  $A \geq -3$  dB

The -3 dB point is also called the *half power point* since

$$10 \log_{10} \frac{P_o}{P_i} = 10 \log_{10} \frac{V_o^2}{V_i^2} = 10 \log_{10} (A)^2 = 10 \log_{10} \left( \frac{1}{\sqrt{2}} \right)^2 = 10 \log_{10} \frac{1}{2} = -3 \text{ dB}$$

### 5.3.2 High Pass Filter

A high pass filter, as the name suggests, *allows* high frequencies to pass through the circuit whilst low frequencies are attenuated or blocked. The cut-off point or bandwidth concept is the same as in the low pass filter.

In practise, the same circuit used for the low pass filter can be adopted as a high pass filter with the output taken across the resistor this time. The resulting schematic is shown in Figure 5.5(a).

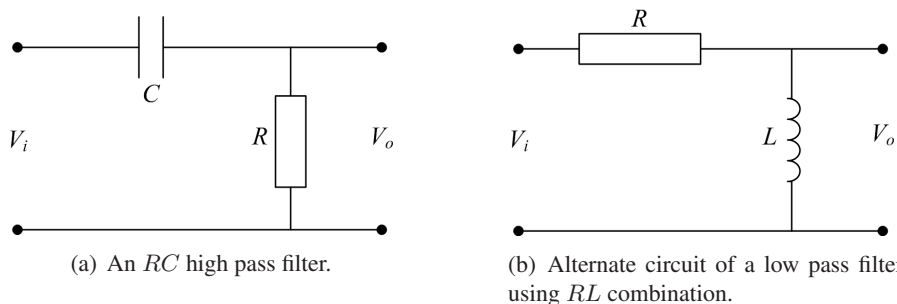

**Figure 5.5:** Two alternate circuit configurations used to construct a high pass filter.

As before, VDR can be applied to determine the output voltage across the resistor in Figure 5.5(a).

$$V_o = V_i \frac{R}{R + \frac{1}{j\omega C}}$$

$$\frac{V_o}{V_i} = \frac{1}{1 + \frac{1}{j\omega RC}}$$

Clearly, when  $\omega \approx 0$ ,  $V_o \approx 0$ , and for  $\omega \rightarrow \infty$ ,  $V_o \rightarrow V_i$ . Hence at high frequencies, most of the input voltage appears at the output making this circuit as a high pass filter.

The frequency response diagrams are depicted in Figure 5.6 showing low gain at low frequencies with gain approaching 1 for high frequencies. The phase plot varies from  $90^\circ$  to  $0^\circ$  with the cutoff frequency,  $\omega = 1/T$ , crossing at  $45^\circ$ .

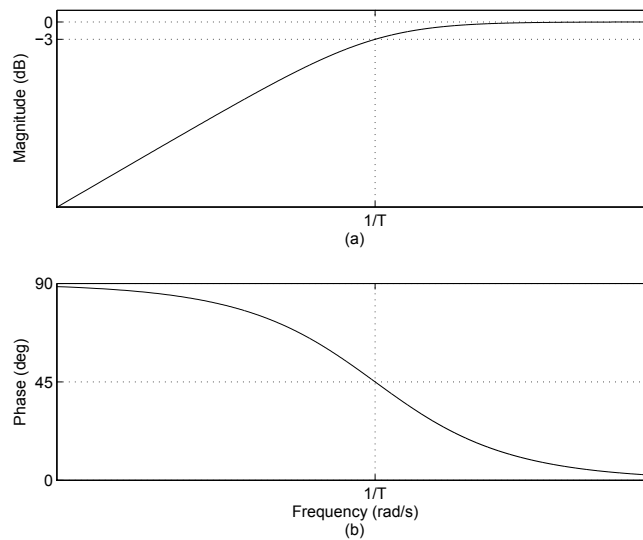

**Figure 5.6:** Frequency response of a high pass filter where (a) Amplitude response (b) Phase response.

### 5.3.3 Band Pass Filter

A band pass filter permits a certain *band* of frequencies to pass through the network which is adjusted by the designer. It is simply an amalgamation of a low pass and a high pass filter. If Figures 5.5(a) and 5.2(a) are joined in cascade, a high pass filter can be constructed as shown in Figure 5.7. In this case, there are two resistors and two capacitors whose values can be altered to tune the desired band.

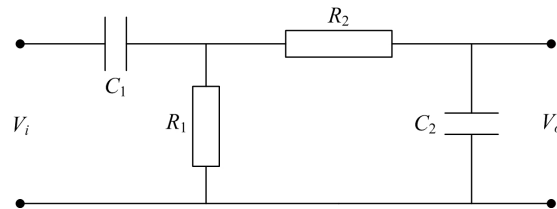

**Figure 5.7:** Schematic of a band pass filter.

The amplitude and phase response of a band pass filter is shown in Figure 5.8 highlighting the two cutoff frequencies  $\omega_1$  and  $\omega_2$ . All frequencies within this range in an input signal will be allowed to pass unaltered through the circuit whilst any frequency outside these limits will be blocked or severely attenuated.

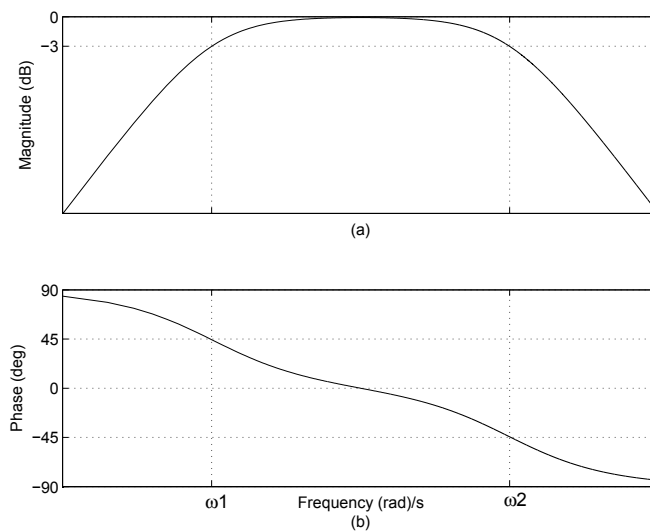

**Figure 5.8:** Frequency response of a band pass filter

## 5.4 Bode Plots

Bode plots are a graphical way to display the behaviour of a circuit over a wide range of frequencies. By plotting the amplitude and phase versus the logarithm of frequency, each unit of change on the  $\omega$  axis is equal to a factor of 10 also called a *decade* of frequency. Also, there may be a wide distribution in the amplitude response over a specified range of frequencies. The usual way is to plot the amplitude in dB and phase in degrees or radians versus the logarithm of frequency. The frequency response diagrams depicted in Figures 5.4, 5.6 and 5.8 are all Bode plots.

### 5.4.1 Approximate Bode Plots

Another advantage of using Bode plots is the easiness through which they can be sketched using a simple graphical technique which is particularly very useful for complicated transfer functions. In this method, the numerator and denominator polynomials are factorised which are then treated individually. Asymptotic plots are drawn for each first and second order factors by following some simple rules. The resultant Bode plot is obtained by simply adding all the individual plots. This is another rationale of employing logarithmic units since  $\log(AB) = \log A + \log B$ .

Consider the voltage transfer function of an electric circuit in factored form as follows

$$H(j\omega) = \frac{K(1 + j\omega T_1)}{(j\omega)^2(1 + j\omega T_2)(1 + \omega T_2)}$$

where  $K$  is a constant gain and  $T_1$ ,  $T_2$  and  $T_3$  are the three time constants. The factor in the numerator is a *zero* whereas the two denominator factors are called the *poles*. The term  $j\omega$  in the denominator is a second order integrator.

Let  $A_1\angle\phi_1$ ,  $A_2\angle\phi_2$  and  $A_3\angle\phi_3$  represents the magnitudes and phases of the single zero and two poles of  $H(j\omega)$  respectively. Then the combined amplitude and phase can be written in polar form as

$$\mathbf{H}(j\omega) = A\angle\phi$$

where

$$A = \frac{KA_1}{\omega^2 A_2 A_3} \text{ and } \phi = \angle(\phi_1 - \phi_2 - \phi_3 - 180^\circ) \quad (5.5)$$

In dB units, the gain can be specified as

$$A_{dB} = 20 \log_{10} K + 20 \log_{10} A_1 - 20 \log_{10} \omega^2 - 20 \log_{10} A_2 - 20 \log_{10} A_3$$

Hence the individual plots can be simply added to find the resultant amplitude response. In the following, some simple rules are outlined to draw the approximate or asymptotic Bode amplitude and phase plots.

**Amplitude Response** The amplitude response curve is the magnitude of the given transfer function in dB versus the logarithm of frequency,  $\omega$  in rad/s.

- For a constant gain,  $K$ , the amplitude is a horizontal line of magnitude  $20 \log_{10} K$  (Figure 5.9(a)).
- For a simple zero of order 1, the gain is 0 in the interval,  $\omega \leq 1/T$  and increases at a rate of +20 dB/decade afterwards (Figure 5.10(a)).
- For a simple zero of order  $n$ , the gain is 0 in the interval,  $\omega \leq 1/T$  and increases at a rate of  $+20 \times n$  dB/decade afterwards.

- For a simple pole of order 1, the gain is 0 in the interval,  $\omega \leq 1/T$  and then decreases at a rate of -20 dB/decade (Figure 5.11(a)).
- For a simple pole of order  $n$ , the gain is 0 in the interval,  $\omega \leq 1/T$  and then decreases at a rate of  $-20 \times n$  dB/decade.
- For a differentiator of order  $n$  i.e.  $H(j\omega) = (j\omega T)^n$ , the magnitude is a constant ramp with a slope of  $+20 \times n$  dB/decade crossing the 0 dB line at a break frequency of  $\omega = 1/T$  rad/s (see Figure 5.12(a) for a first order differentiator).
- For an integrator of order  $n$ , the magnitude is a constant ramp with a slope of slope  $-20 \times n$  dB/decade crossing the 0 dB line at a break frequency of  $\omega = 1/T$  rad/s (see Figure 5.13(a) for a first order integrator).

Note that all amplitude response curves have either a slope of zero or  $\pm 20 \times n$  dB/decade where  $n$  is the order of numerator or denominator factors.

**Phase Response** The phase response plot is the phase of the given transfer function in degrees or radians versus the logarithm of frequency,  $\omega$  in rad/s.

- For a constant gain,  $K$ , the phase response is a constant  $0^\circ$  horizontal line (Figure 5.9(b)).
- For a simple zero of order 1, the phase angle is  $0^\circ$  until  $0.1/T$ , then rises at the rate of  $45^\circ$ /decade and settles at  $90^\circ$  for  $\omega \geq 10/T$  (Figure 5.10(b)).

**gaiteye**  
Challenge the way we run

**EXPERIENCE THE POWER OF FULL ENGAGEMENT...**

**RUN FASTER.  
RUN LONGER..  
RUN EASIER...**

**READ MORE & PRE-ORDER TODAY  
WWW.GAITEYE.COM**



- For a simple zero of order  $n$ , the phase is  $0^\circ$  until  $0.1/T$ , then rises at the rate of  $45^\circ \times n/\text{decade}$  and settles at  $90^\circ \times n$  for  $\omega \geq 10/T$ .
- For a simple pole of order 1, the phase is  $0^\circ$  until  $0.1/T$ , then falls at the rate of  $-45^\circ/\text{decade}$  and settles at  $-90^\circ$  for  $\omega \geq 10/T$  (Figure 5.11(b)).
- For a simple pole of order  $n$ , the phase is  $0^\circ$  until  $0.1/T$ , then drop-off at the rate of  $-45^\circ \times n/\text{decade}$  and settles at  $-90^\circ \times n$  for  $\omega \geq 10/T$ .
- For a differentiator of order  $n$  i.e.  $H(j\omega) = (j\omega T)^n$ , the phase plot is a constant line of  $90^\circ \times n$  (see Figure 5.12(b) for a first order differentiator).
- For an integrator of order  $n$ , the phase response is a horizontal line of  $-90^\circ \times n$  (see Figure 5.13(b) for a first order integrator). In Equation 5.5, the  $180^\circ$  term in the phase angle is due to the 2nd order integrator.

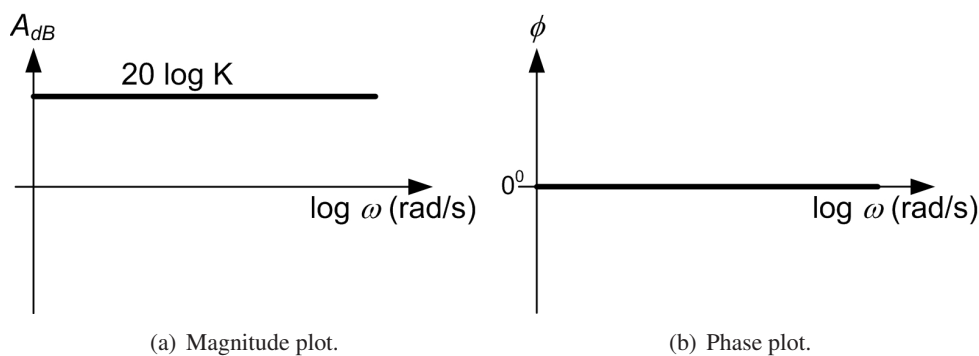

Figure 5.9: Asymptotic Bode plots of a constant gain.

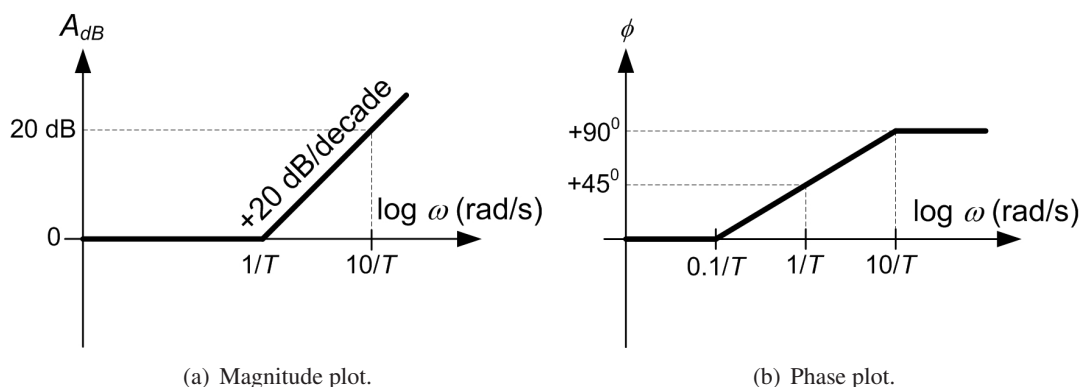
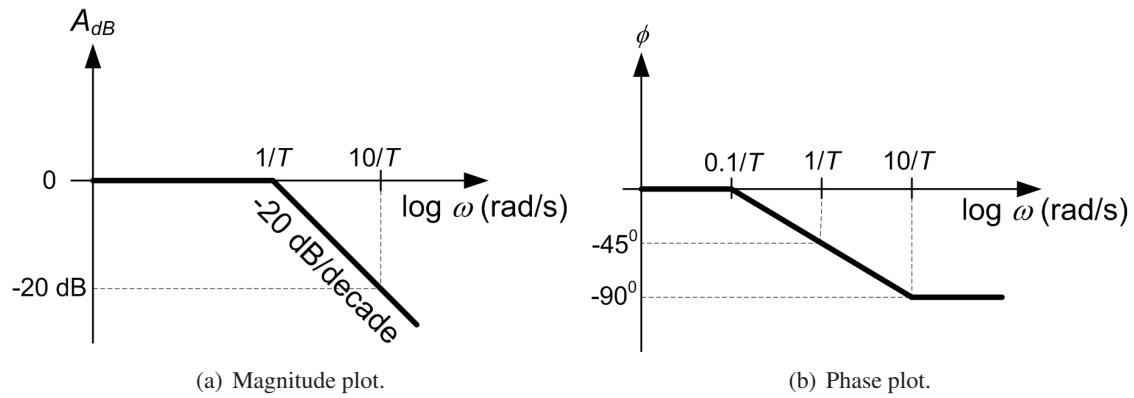
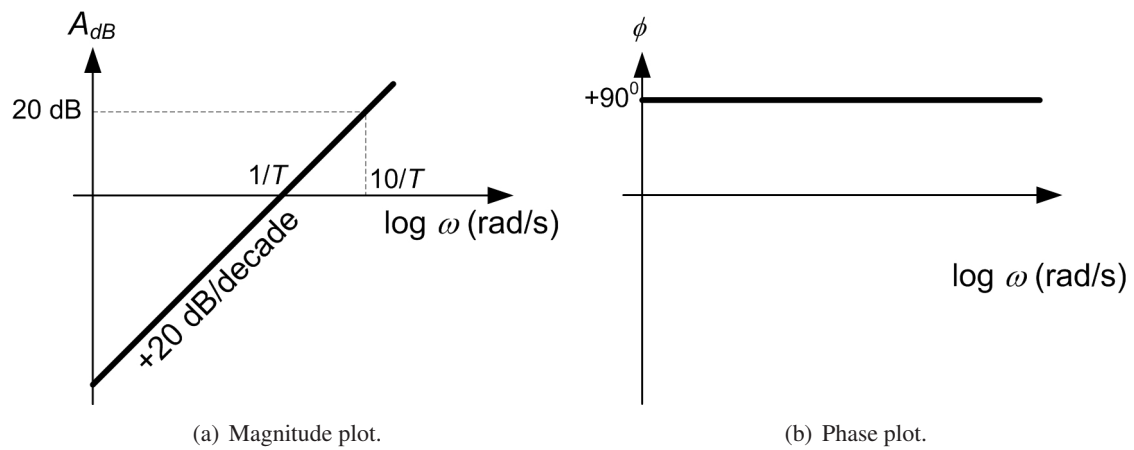

Figure 5.10: Asymptotic Bode plots of a simple zero of order 1.



**Figure 5.11:** Asymptotic Bode plots of a simple pole of order 1.



**Figure 5.12:** Asymptotic Bode plots of a first order differentiator.

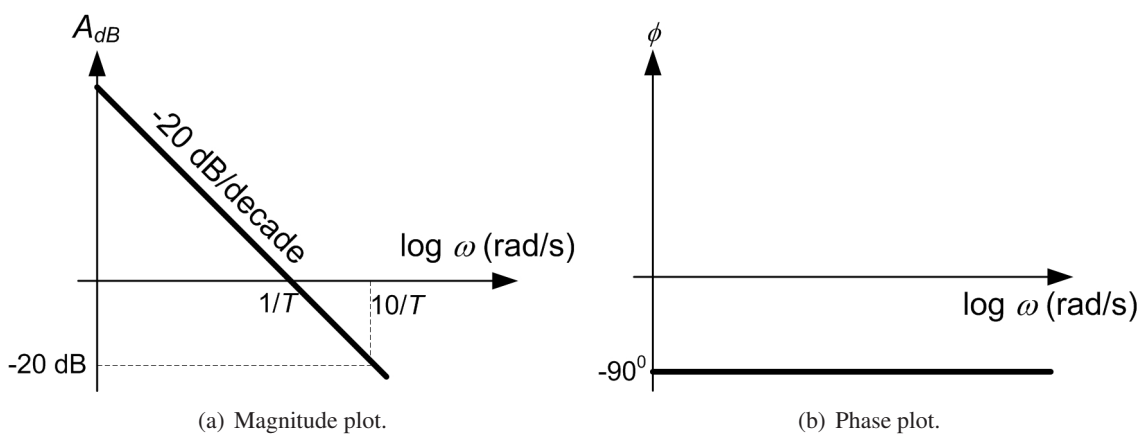

**Figure 5.13:** Asymptotic Bode plots of a first order integrator.

**Example**

Draw the approximate Bode plots of the following transfer function

$$H(j\omega) = \frac{10(1 + j\omega 2)}{(j\omega 5)(1 + j\omega 10)^2} \tag{5.6}$$

The above transfer function consists of a simple zero, a second order pole and an integrator. This can be rearranged in the standard form as below

$$H(j\omega) = \frac{(1 + j\omega/0.5)}{(j\omega/2)(1 + j\omega/0.1)^2}$$

where 0.5, 0.1 and 2 rad/s are the break frequencies of the simple zero, double pole and integrator respectively. From the rules outlined above, Bode plot can be drawn by inspection as demonstrated in Figure 5.14.

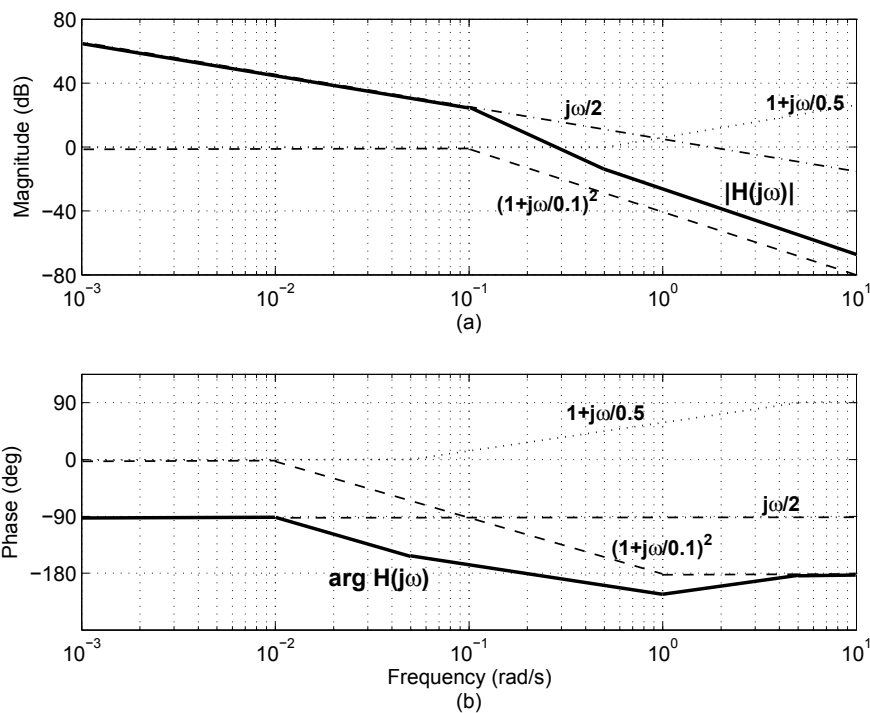

**Figure 5.14:** Approximate Bode plot for the transfer function in Equation 5.6 where (a) Amplitude response and (b) Phase response.

## Appendix A

# Cramer's Rule

Given two or more simultaneous system of equations, a convenient way to solve for the unknown variables is the application of Cramer's rule as explained below.

Consider three equations with unknown variables  $x_1$ ,  $x_2$  and  $x_3$  as follows:

$$a_{11}x_1 + a_{12}x_2 + a_{13}x_3 = b_{11} \quad (\text{A.1})$$

$$a_{21}x_1 + a_{22}x_2 + a_{23}x_3 = b_{21} \quad (\text{A.2})$$

$$a_{31}x_1 + a_{32}x_2 + a_{33}x_3 = b_{31} \quad (\text{A.3})$$

where  $a_{ij}$  and  $b_{i1}$  are constants and  $i, j = 1, 2, 3$ .

This e-book  
*is made with*  
**SetaPDF**





PDF components for **PHP** developers

**[www.setasign.com](http://www.setasign.com)**

In matrix form, the above equations can be written as

$$\begin{bmatrix} a_{11} & a_{12} & a_{13} \\ a_{21} & a_{22} & a_{23} \\ a_{31} & a_{32} & a_{33} \end{bmatrix} \begin{bmatrix} x_1 \\ x_2 \\ x_3 \end{bmatrix} = \begin{bmatrix} b_{11} \\ b_{21} \\ b_{31} \end{bmatrix}$$

To determine  $x_1$ ,  $x_2$  and  $x_3$ , the following determinants are evaluated

$$\Delta = \begin{vmatrix} a_{11} & a_{12} & a_{13} \\ a_{21} & a_{22} & a_{23} \\ a_{31} & a_{32} & a_{33} \end{vmatrix}$$

$$\Delta_1 = \begin{vmatrix} b_{11} & a_{12} & a_{13} \\ b_{21} & a_{22} & a_{23} \\ b_{31} & a_{32} & a_{33} \end{vmatrix}$$

$$\Delta_2 = \begin{vmatrix} a_{11} & b_{11} & a_{13} \\ a_{21} & b_{21} & a_{23} \\ a_{31} & b_{31} & a_{33} \end{vmatrix}$$

$$\Delta_3 = \begin{vmatrix} a_{11} & a_{12} & b_{11} \\ a_{21} & a_{22} & b_{21} \\ a_{31} & a_{32} & b_{31} \end{vmatrix}$$

Then  $x_1$ ,  $x_2$  and  $x_3$  can be found according to the following equations

$$\begin{aligned} x_1 &= \frac{\Delta_1}{\Delta} \\ x_2 &= \frac{\Delta_2}{\Delta} \\ x_3 &= \frac{\Delta_3}{\Delta} \end{aligned}$$